

ELECTRICAL MEASUREMENT & INSTRUMENTATION

4TH SEM ELECTRICAL ENGG.



UNIT-1

MEASURING INSTRUMENTS

Accuracy:

The error between the real and measured value.

Precision:

The random spread of measured values around the average measured values.

Resolution:

The smallest to be distinguished magnitude from the measured value.

Sensitivity:

The ability of the measuring instrument to respond to changes in the measured quantity. It is expressed as the ratio of the change of output signal or response of the Instrument to a change of input or measured variable.

Error:

Deviation from the true value of the measured variable.

Classification of measuring instruments

Definition of instruments

An instrument is a device in which we can determine the magnitude or value of the quantity to be measured. The measuring quantity can be voltage, current, power and energy etc.

Generally instruments are classified in to two categories.

- Absolute Instrument
- Secondary Instrument

Absolute instrument

An absolute instrument determines the magnitude of the quantity to be measured in terms of the instrument parameter. This instrument is really used, because each time the value of the

measuring quantities varies. So we have to calculate the magnitude of the measuring quantity, analytically which is time consuming. These types of instruments are suitable for laboratory use.

Example: Tangent galvanometer.

Secondary instrument

This instrument determines the value of the quantity to be measured directly. Generally these instruments are calibrated by comparing with another standard secondary instrument.

Examples of such instruments are voltmeter, ammeter and wattmeter etc. Practically secondary instruments are suitable for measurement.

Secondary instruments

- Indicating instruments
- Recording
- Integrating
- Electromechanically Indicating instruments

Indicating instrument

This instrument uses a dial and pointer to determine the value of measuring quantity. The pointer indication gives the magnitude of measuring quantity.

Recording instrument

This type of instruments records the magnitude of the quantity to be measured continuously over a specified period of time.

Integrating instrument

This type of instrument gives the total amount of the quantity to be measured over a specified period of time.

Electromechanical indicating instrument

For satisfactory operation electromechanical indicating instrument, three forces are necessary. They are

- (a) Deflecting force
- (b) Controlling force
- (c) Damping force

Deflecting force

When there is no input signal to the instrument, the pointer will be at its zero position. To deflect the pointer from its zero position, a force is necessary which is known as deflecting force. A system

which produces the deflecting force is known as a deflecting system. Generally a deflecting system converts an electrical signal to a mechanical force.

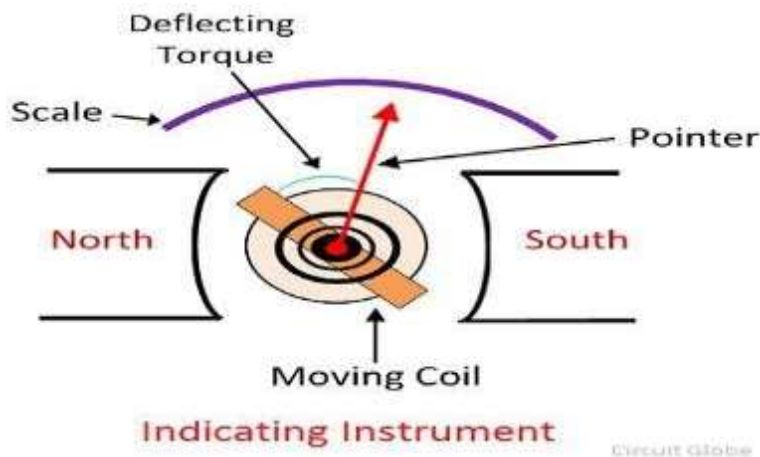

Controlling force

To make the measurement indicated by the pointer definite (constant) a force is necessary which will be acting in the opposite direction to the deflecting force. This force is known as controlling force. A system which produces this force is known as a controlled system. When the external signal to be measured by the instrument is removed, the pointer should return back to the zero position. This is possibly due to the controlling force and the pointer will be indicating a steady value when the deflecting torque is equal to controlling torque.

$$T_d = T_c$$

Spring control

Two springs are attached on either end of spindle (Fig. 1.5). The spindle is placed in jewelled bearing, so that the frictional force between the pivot and spindle will be minimum. Two springs are provided in opposite direction to compensate the temperature error. The spring is made of phosphorous bronze. When a current is supply, the pointer deflects due to rotation of the spindle. While spindle is rotate, the spring attached with the spindle will oppose the movements of the pointer. The torque produced by the spring is directly proportional to the pointer deflection.

T_c proportional Θ

The deflecting torque produced T_d proportional to 'I'. When $T_c = T_d$, the pointer will come to a steady position. Therefore

$$\Theta \text{ proportional } I$$

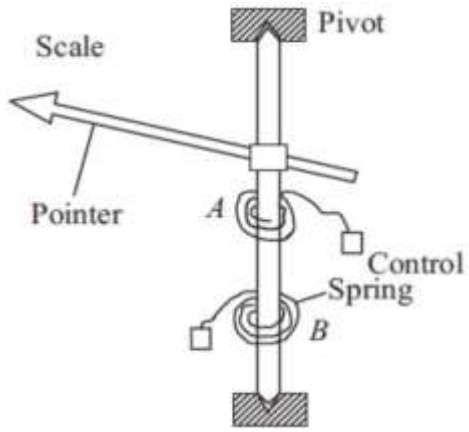

Damping force

The deflection torque and controlling torque produced by systems are electro mechanical. Due to inertia produced by this system, the pointer oscillates about its final steady position before coming to rest. The time required to take the measurement is more. To damp out the oscillation quickly, a damping force is necessary. This force is produced by different systems.

- (a) Air friction damping
- (b) Fluid friction damping
- (c) Eddy current damping

Air friction damping

The piston is mechanically connected to a spindle through the connecting rod. The pointer is fixed to the spindle and moves over a calibrated dial. When the pointer oscillates in clockwise direction, the piston goes inside and the cylinder gets compressed. The air pushes the piston upwards and the pointer tends to move in anticlockwise direction.

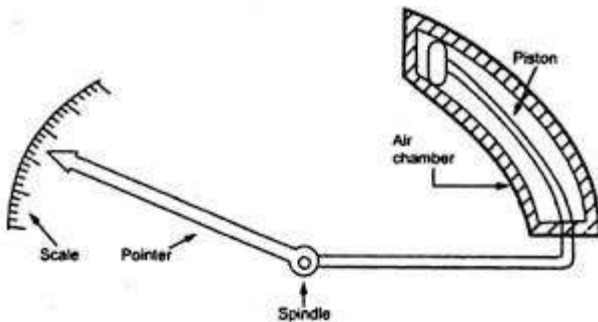

If the pointer oscillates in anticlockwise direction the piston moves away and the pressure of the air inside cylinder gets reduced. The external pressure is more than that of the internal pressure. Therefore the piston moves downwards. The pointer tends to move in clockwise direction.

Eddy current damping

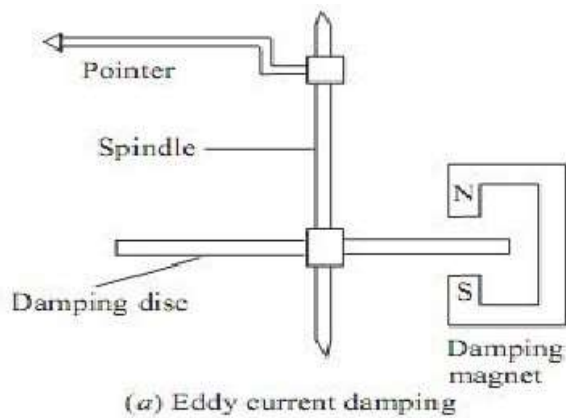

An aluminum circular disc is fixed to the spindle. This disc is made to move in the magnetic field produced by a permanent magnet. When the disc oscillates it cuts the magnetic flux produced by damping magnet. An emf is induced in the circular disc by faradays law. Eddy currents are established in the disc since it has several closed paths. By Lenz's law, the current carrying disc produced a force in a direction opposite to oscillating force. The damping force can be varied by varying the projection of the magnet over the circular disc.

Fluid friction damping

This form of damping is similar to air friction damping. The action is the same as in the air friction damping. Mineral oil is used in place of air and as the viscosity of oil is greater, the damping force is also much greater. The vane attached to the spindle is arranged to move in the damping oil.

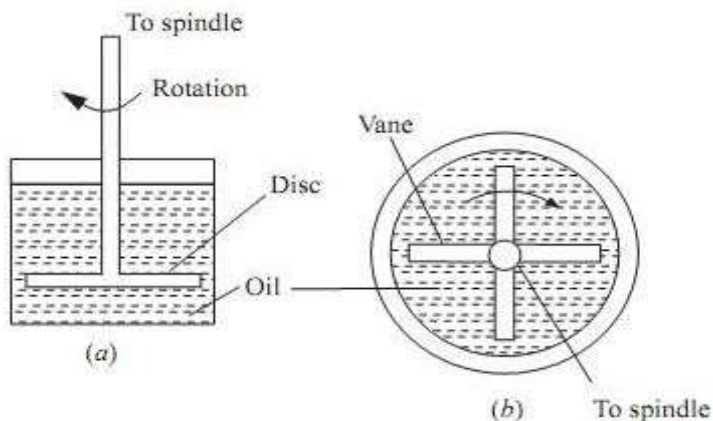

In Fig. (a) a disc attached to the moving system is immersed in the fluid (damping oil). When the moving system moves the disc moves in oil and a frictional drag is produced. For minimizing the surface tension affect, the suspension stem of the disc should be cylindrical and of small diameter.

In the arrangement of Fig. (b) a number of vanes are attached to the spindle. These vanes are submerged in oil and moves in a vertical plane. This arrangement provides greater damping torque.

Calibration of instruments

Calibration of the measuring instrument is the process in which the readings obtained from the instrument are compared with the sub-standards in the laboratory at several points along the scale of the instrument.

All the new instruments have to be calibrated against some standard in the very beginning. For the new instrument the scale is marked as per the sub-standards available in the laboratories, which are meant especially for this purpose. After continuous use of the instrument for long periods of time, sometimes it loses its calibration or the scale gets distorted, in such cases the instrument can be calibrated again if it is in good reusable condition.

Even if the instruments in the factory are working in the good condition, it is always advisable to calibrate them from time-to-time to avoid wrong readings of highly critical parameters.

How Calibration of the Instruments is done?

There are different methods or techniques of calibration, which are applied depending on whether it is routine calibration or if it is for special purpose where highly accurate calibration of the instruments is desired. In many cases different methods of calibration are applied for all the individual instruments.

The calibration of the instrument is done in the laboratory against the sub-standard instruments, which are used very rarely for this sole purpose. These sub-standards are kept in highly controlled air-conditioned atmosphere so that there their scale does not change with the external atmospheric changes.

To maintain the accuracy of the sub-standards, they are checked periodically against some standard which is kept in the metrological laboratories under highly secured, safe, clean and air conditioned atmosphere.



UNIT-2

ANALOG AMMETERS AND VOLTMETERS

Moving iron type instruments:

Definition: The instrument in which the moving iron is used for measuring the flow of current or voltage is known as the moving iron instrument.

Classification of the Moving Iron Instruments:

1. Attraction Type
2. Repulsion Type

Attraction Type Instrument – The stationary coil of the attraction type instrument is flat and has a narrow opening. The moving element is the flat disc of the iron core. The current flow through the stationary coil produced the magnetic field which attracts the iron coil.

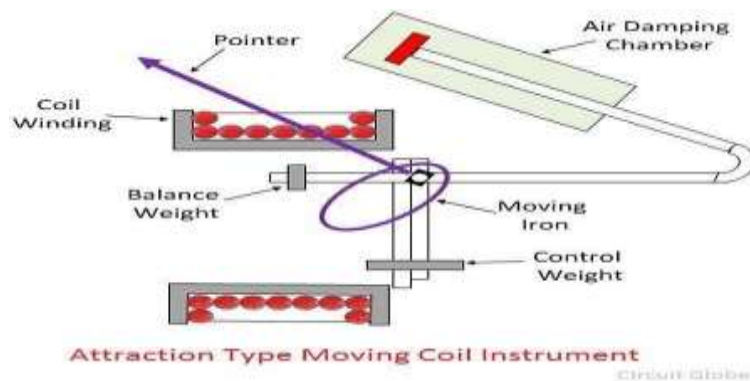

The iron vane deflects from the low magnetic field to the high magnetic field, and the strength of the deflection is directly proportional to the magnitude of the current flow through it. In short, we can say that the iron coil attracts towards in.

The attraction type instruments use spring, which provided the controlling torque. The deflection of the coil is reduced by the aluminium piston which is attached to the moving coil.

Repulsion Type Instruments – The repulsion type instrument has two vanes or iron plates. One is fixed, and the other one is movable. The vanes become magnetized when the current passes through the stationary coil and the force of repulsion occur between them. Because of a repulsive force, the moving coil starts moving away from the fixed vane.

The spring provides the controlling torque. The air friction induces the damping torque, which opposes the movement of the coil. The repulsion type instrument is a non-polarized instrument, i.e., free from the direction of current passes through it. Thus, it is used for both AC and DC.

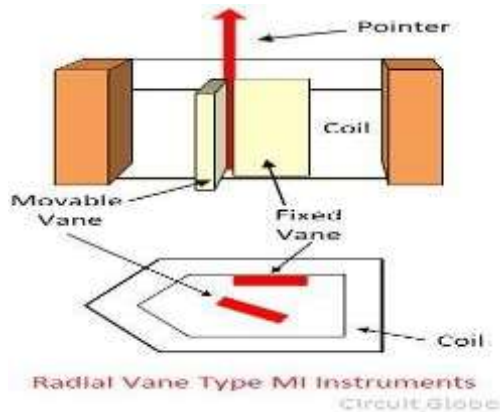

Advantages of the MI Instruments:

Universal use – The MI instrument is independent of the direction of current and hence used for both AC and DC.

Less Friction Error – The friction error is very less in the moving iron instrument because their torque weight ratio is high. The torque weight ratio is high because their current carrying part is stationary and the moving parts are lighter in weight.

Cheapness – The MI instruments require less number of turns as compared to PMMC instrument. Thus, it is cheaper.

Robustness – The instrument is robust because of their simple construction. And also because their current carrying part is stationary.

Disadvantages of Moving Iron Instruments:

Accuracy – The scale of the moving iron instruments is not uniform, and hence the accurate result is not possible.

Errors – Some serious error occurs in the instruments because of the hysteresis, frequency and stray magnetic field.

Waveform Error – In MI instrument the deflection torque is not directly proportional to the square of the current. Because of which the waveforms error occurs in the instrument.

Difference between AC and DC calibration – The calibration of the AC and DC are differed because of the effect of the inductance of meter and the eddy current which is used on AC. The AC is calibrated on the frequency at which they use.

Errors in Moving Iron Instruments:

There are two types of errors which occur in moving iron instruments:

- Errors with both AC and DC.
- Errors with AC only.

Errors with both AC and DC

The following are the main errors in moving iron instruments, when these are used either on DC or AC.

Error due to hysteresis: Because of hysteresis in the iron parts of the operating system, the readings are higher for descending values but lower for ascending values. The hysteresis error is considerably reduced by using mumetal or permalloy which have negligible hysteresis loss.

Error due to stray magnetic fields: Since the operating magnetic field of the moving iron instruments is comparatively weak, therefore, stray fields (fields other than the operating magnetic field) affect these instruments considerably. Thus the stray fields cause serious errors. These errors can be minimized by using an iron case or a thin iron shield over the working parts.

Error due to temperature: The effect of temperature change on moving iron instrument arises mainly from the temperature coefficient of spring. With the change in temperature stiffness of the spring varies which causes errors. However, for voltmeters, both the temperature coefficient of spring and temperature coefficient of resistance of voltmeter circuit may balance each other.

Errors with AC only

Error in moving iron instruments due to change in frequency: The change in frequency produces a change in impedance of the coil and change in magnitude of eddy currents. The increase in impedance of the coil with the increase in frequency causes serious errors in case of voltmeters only.

However, this error can be eliminated by connecting a condenser of suitable value in parallel with the swamp resistance 'r' of the instrument.

Permanent Magnet Moving coil type instruments:

Construction of PMMC Instruments

Permanent Magnet Moving Coil or PMMC Instruments consists of following components:

- Moving Coil
- Magnet System
- Control Spring
- Damping
- Pointer and Scale

Moving Coil:

The moving coil made up of copper is wound with many turns on the rectangular Aluminum former. This Aluminum former is pivoted on the jewelled bearing. The coil can move freely in the magnetic field produced by the Permanent Magnet System.

Magnet System:

Simple U shaped permanent magnet made of Alcomax or Alnico is widely use in PMMC instruments. Theses magnets have high coercive force and can produce field of the order of 0.1 to 1 Wb/m². A soft iron end cylinder is bored in between the poles to make the field radial and uniform.

Control Spring:

The controlling torque in PMMC Instruments is provided by two control spring mounted on the jewel bearing. Theses control springs are phosphor bronze hair spring either helical or spiral, coiled in opposite direction. Control Spring also serves to lead current in and out of the moving coil.

Pointer and Scale:

The pointer is carried by the spindle and moves over a graduated scale. The pointer is of light weight construction and has a section over the scale twisted to form a fine blade. This helps in reducing the Parallax Error in reading the scale.

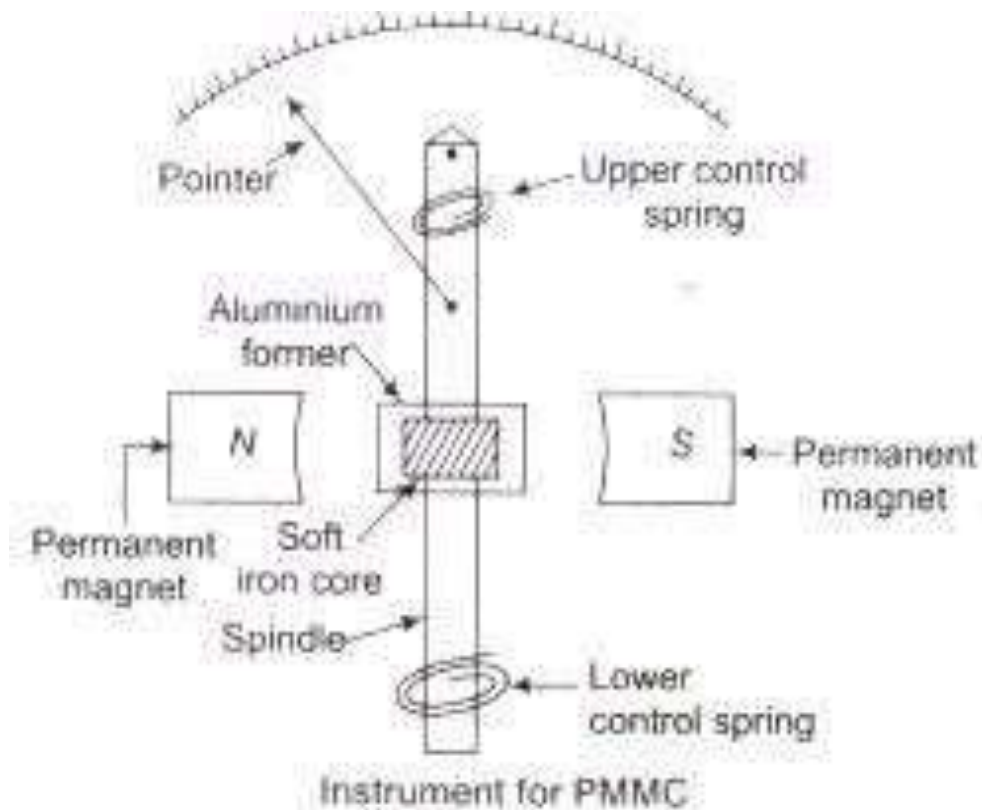

Torque Equation for PMMC Instruments:

The deflecting torque equation for Permanent Magnet Moving Coil or PMMC Instruments is given as

$$\text{Deflecting Torque } T_d = NBLdI = GI$$

Where $G = \text{a constant} = NBLd$

Where $N = \text{Number of turns in the moving coil}$

$B = \text{magnetic flux density between the magnetic poles}$

$L = \text{Length of moving coil}$

$d = \text{Breadth of moving coil}$

As the controlling torque is provided by the spring, therefore

$$T_c = K\Theta$$

Where $K = \text{Spring constant}$

$\Theta = \text{Angular movement of coil}$

At steady state condition, deflecting and controlling torque shall be equal,

$$T_d = T_c$$

$$\Rightarrow GI = K\Theta$$

$$\Rightarrow \Theta = (G / K) I \dots\dots\dots (1)$$

Thus from the above equation (1), we observe that deflection in Permanent Magnet Moving Coil or PMMC Instruments is directly proportional to the current flowing in the moving coil. Because of this the meter scale of such instrument for the measurement of current / voltage is linear.

ADVANTAGES OF PMMC INSTRUMENT

1. They have low power consumption.
2. Such instruments have uniform calibrated scale.
3. They have high torque/weight ratio.
4. They have no hysteresis loss.
5. They have very effective and efficient Eddy current damping.
6. They are not much affected by stray magnetic field.

DISADVANTAGES OF PMMC INSTRUMENT

1. Due to delicate construction, necessary accurate machining and assembly of various parts , such instruments are somewhat costlier as compared to moving iron instruments.
2. Some errors are set in due to the aging of control springs and permanent magnets.

Error in PMMC Equipment-

1. Error due to magnetism

Permanent magnet loose their magnetism with time; this is called magnet aging. With plenty of heat and vibration on ship. There is reduction of magnetism due to accelerated aging. This decrease in magnetic strength reduce the coil deflection affecting the readings.

2. Error due to Temperature Difference

Moving Coil of PMMC instrument is made up of copper wires; the temperature coefficients of copper wire is known to be 0.004 per degree Celsius. So with increase in temperature, there will be high increase in its resistance altering the actual reading.

3. Error Due to Spring

Aging leads to weakening of spring tension; this results in decreased deflection of the moving coil. This error is opposite to that of the error due to magnetic aging and sometimes cancel each other to reduce much difference in the final readings.

Dynamometer type instruments:

CONSTRUCTION-

The coils of dynamometer are usually air-cored which avoids hysteresis, eddy currents and other errors when the instrument is used on AC. The fixed coil is divided into two halves connected in series with the moving coil. And placed together and parallel to each so as to provides a fairly uniform field within the range of the movement of the coil. However, the space between the two halves of the fixed coil must be sufficient enough to allow the movement of the moving coil shaft.

Two hair strings are used to create controlling torque in the instrument which also serves the purpose of lead to the moving coil a section damping is usually provided in such a instrument.

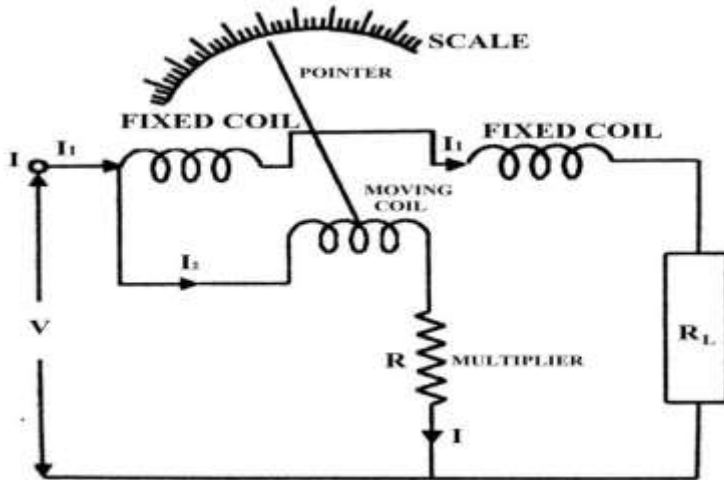

Dynamometer develops deflecting torque by the interaction of magnetic fields. One field is due to the current in a moving coil. And the other field is due to the current in the fixed coil. The field due to the coil is not constant but varies with the magnitude of the current flowing through the fixed coil. Hence the deflecting torque of this instrument is determined not only by moving coil current but also by fixed coil current. This instrument with its fixed and moving coil connected in series is adapted for voltage measurement as shown in figure.

Dynamometer is rarely used as an ammeter by following reasons:

The lead-in spiral to the moving coil can carry limited current.

Frequency variation influence the inductance of the coil and introduce error.

The resistance of the moving and fixed coil in series may cause undesirable high voltage across the instrument.

Since the deflecting torque is determined by variations in either the field or the moving coil currents. So the dynamometer instrument is a versatile measuring device for several other applications such as for measurement of power reactive volt-ampere. And with some modification for measuring power factor and frequency in AC circuits.

Though these instruments can be used both, for dc and ac measurements. But mostly it is used in AC practically. Because of the following reasons;

- These instruments have highest cost.
- Higher power consumption.
- Lower torque-weight ratio.
- Non uniform scale.

Advantages of Dynamometer

- As the instrument has Square Law response so can be used on both the dc as well as on AC.
- These instruments are free from hysteresis and Eddy current errors. It is because of absence of iron in the operating part of the instrument.
- Ammeter up to 10A and voltmeter up to 600V can be constructed with precision grade accuracy.

- Dynamo type voltmeters are useful for accurate measurement of rms value of voltage irrespective of waveform.
- Because of Precision grade accuracy and same calibration for DC and AC measurement instruments are used as transfer and calibration instruments.

Disadvantage of Dynamometer

- The scale is not uniform as the instrument uses Square Law response. These instruments have small torque-weight ratio so the friction error is considerable.
- Owing to heavy moving system friction losses in these instruments are somewhat more than those in other instruments.
- As a result of measures taken to reduce the frictional errors, their cost is more in comparison to moving iron and PMMC instruments. They are more sensitive to overload and mechanical impact and are to be handled with care.
- Adequate screening of the movements against the stray magnetic field is essential.
- The power consumption of this instrument is comparatively high because of their construction.

Errors in dynamometer type instruments

Frictional Error: Since the coils are air-cored, therefore the magnetic field produced is of small strength. So they require a large number of ampere-turns to create necessary deflecting torque. This result in the heavy moving system. Therefore small torque-weight ratio. Thus the frictional losses in dynamo type instruments are somewhat larger as compared to other instruments.

Temperature errors: Since the operation of dynamo type instrument required considerable power, self-heating in these instrument is appreciable. The error due to self-heating may be much as 1% of full scale deflection.

Error Due to Stray Magnetic field: Since the operating magnetic field produced by the fixed coil. In these instruments is somewhat weaker in comparison to that in the instrument of other type. The operation of these instruments is more sensitive to the stray magnetic field.

Frequency error: The change in frequency causes error due to change in reactance of operating coil. Due to change in magnitude of Eddy current setup in the metal part of the instrument near to operating portion.

Rectifier type instruments:-

Definition: The instrument which uses the rectifying element for measuring the voltage and current is known as the rectifying instruments. The rectifying element converts the alternating current to the direct current which indicates by the DC responsive meter.

Half Wave Rectifier Circuit:

The figure below shows the half-wave rectifying circuit. The rectifying element connects in series with the voltage source, resistance multiplier and the permanent moving coil instrument. The forward resistance of the diode is neglected.

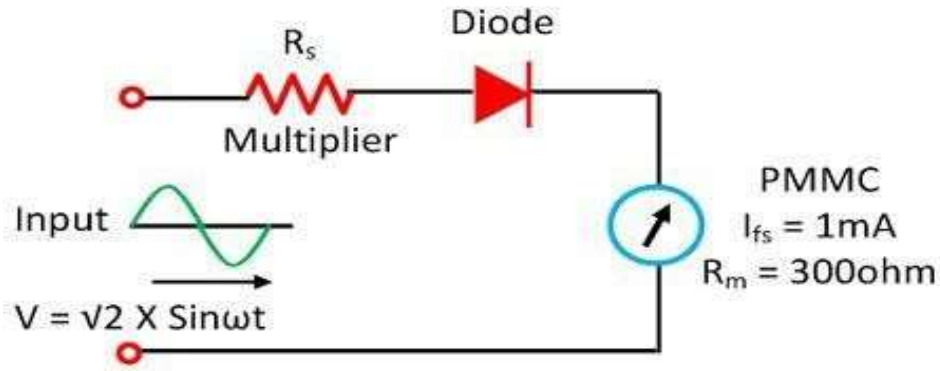

Half Wave Rectifier Circuit

Circuit Globe

When the DC voltage source applies to the circuit, the I_m current flows through it. The magnitude of the current is equal to the $V/(R_m+R_s)$. The current shows the full-scale deflection to the instrument.

The AC voltage applies to the same circuit. The rectifying element converts the AC voltage into unidirectional DC voltage. Thus, the rectified output voltage obtains through the rectify instrument. The PMMC instrument deflects through the average value of current which depends on the average voltage of the apparatus.

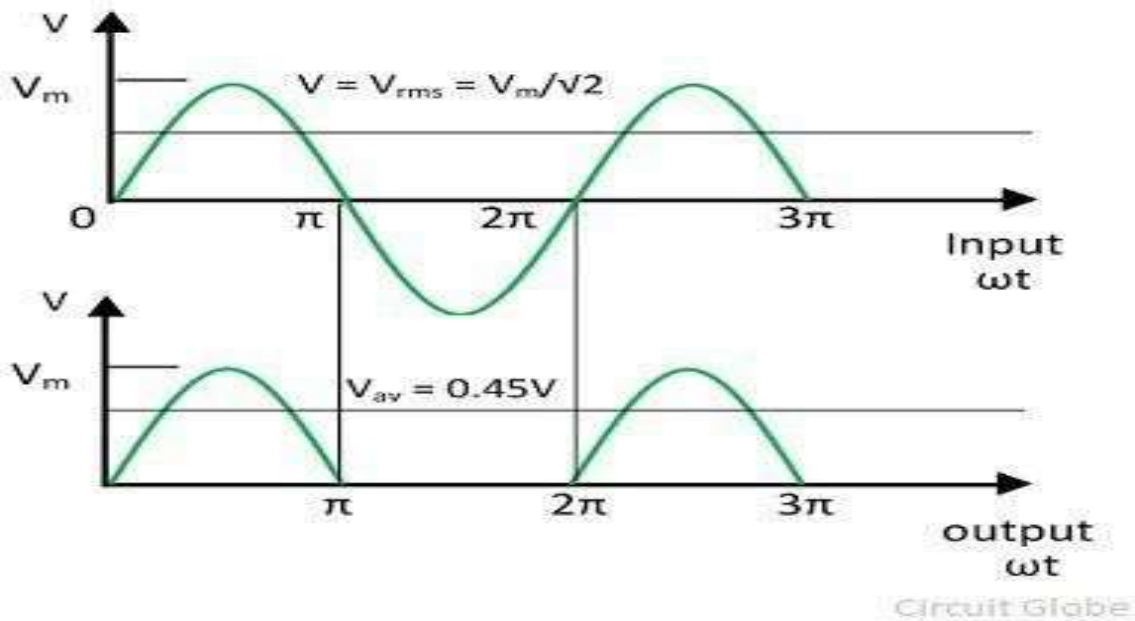

Circuit Globe

Average Value of Voltage

$$V_{av} = \frac{1}{2\pi} \int_0^{\pi} V_m \sin \omega t d(\omega t) = \frac{1}{\pi} V_m$$

$$V_{av} = 0.318V_m$$

$$V_{av} = 0.318 \times \sqrt{2V} = 0.45V$$

The above calculation shows that the sensitivity of the instrument through AC is 0.45 times the current through the sensitivity of DC.

Full Wave Rectifier Instrument:

The circuit of full wave rectifier shown in the figure below.

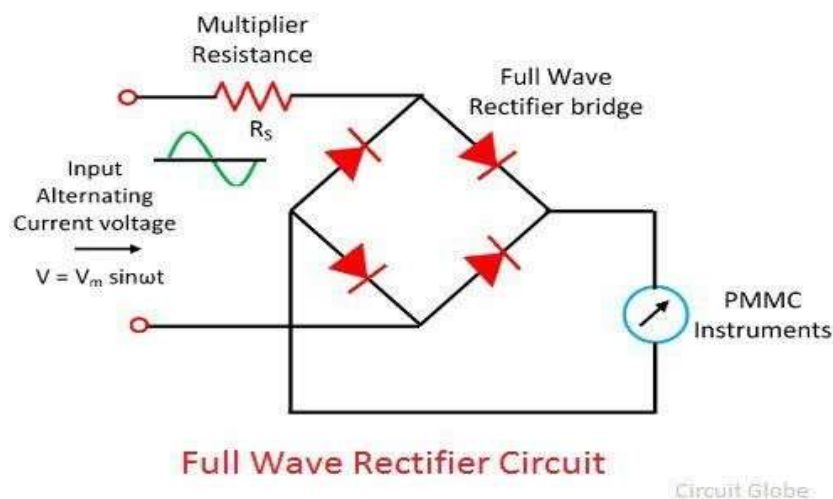

The DC voltage applied to the circuit causes the full-scale deflection of the PMMC meter. The sinusoidal voltage applies to the meter express as

$$V_{av} = \frac{1}{\pi} \int_0^{\pi} V_m \sin \omega t d(\omega t) = \frac{2}{\pi} V_m$$

$$V_{av} = 0.636V_m$$

$$V_{av} = 0.9V$$

The average calculation of AC is 0.9 times with that of the DC for the same value of voltage. Or we can say that the sensitivity of the instrument along with AC is 90% with that of the DC.

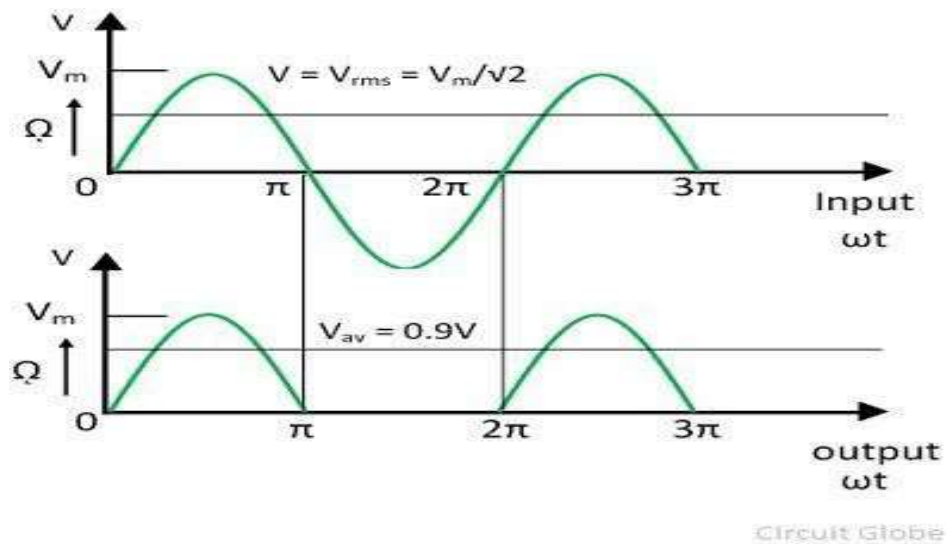

The sensitivity of the full wave rectifier is double to that of the half wave rectifier instrument.

Advantages of Rectifying Instrument

- The frequency range of the instruments increases from 20HZ to high-frequency range.
- The current operating range for such type of instrument is much lower for voltmeter as compared to the other AC instrument.
- The instrument has uniform scales for the large range.
- The accuracy of the instrument is ± 5 percent when it is in normal operating condition.
- Applications of Rectifying Instrument

The following are the applications of the rectifying instrument.

- The instrument uses for measuring the voltage whose range lies between 50 – 250 V.
- It use as a milliammeter or micro-ammeter.
- The rectifying instrument use in the communication circuit for measurement.

Error:

- **Effects of Waveform** – The calibration of the rectifier instrument can be done regarding the RMS value of voltage and current. The form factor of the half wave and the full wave rectifier type instrument fixes on the calibrated scale. And if the waveform of the other form factors applies to the device, the waveform error occurs in the reading.
- **Effect of Temperature Change** – The resistance of the rectifying element varies with the change in temperature. And this property of the rectifying component causes the error in the instruments.
- **Effect of Rectifying Instrument** – The rectifier instrument has the property of the imperfect capacitance. It allows the high-frequency current to pass through it.
- **Decreases in Sensitivity** – The sensitivity of the rectifier type instrument for AC operation is lower than that of the DC operation.

Induction type instruments

SPLIT PHASE TYPE:

PRINCIPLE:

When a disc or drum of a non-magnetic conducting material is placed in a rotating magnetic field, eddy currents are induced in disc or drum. The torque produces with the reaction of rotating magnetic field and eddy current. The relation between torque, eddy current, rotating flux is given below:

$$T \propto \phi \propto i^2$$

CONSTRUCTION:

This instrument convert single phase to two phases. This is also called ferraris type instrument

*It consists of pole which are laminated and placed right angles to each other opposite pole connected in series the two pairs of poles connected in parallel.

*One set of coil is connected to inductance and another with a high resistance to create a phase difference 90. The purpose of both the coils is to measure the current.

*In the centre of yoke, the coil is an aluminium drum, inside drum, to strengthen the magnetic field there is a cylindrical laminated iron core.

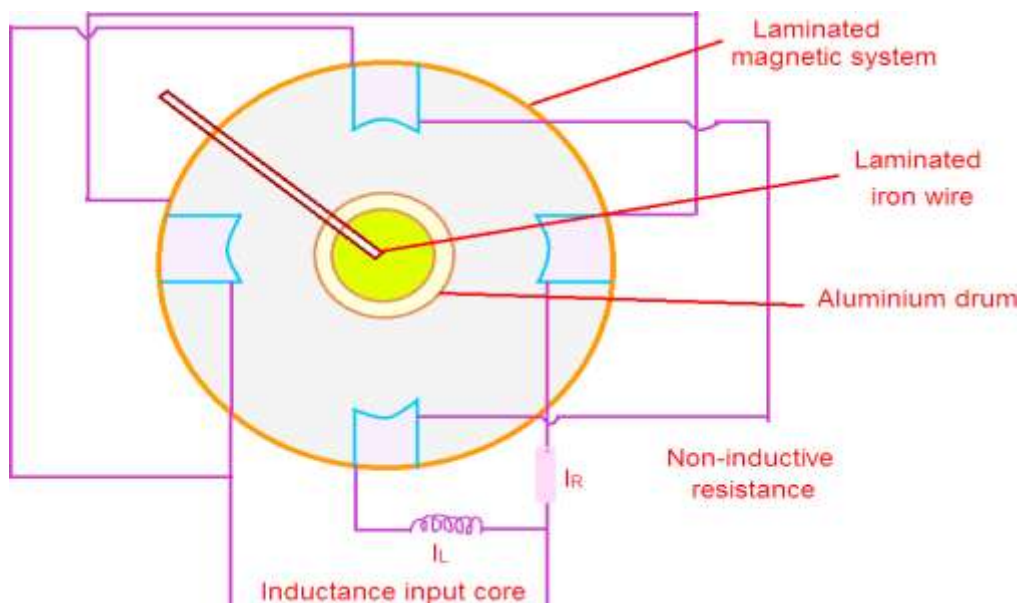

WORKING:

When this instrument is fed with supply due to electromagnets action a rotating magnetic action a rotating magnetic flux produced. This flux induced eddy current in the disc or drum. The reaction between flux and eddy current results in production of torque. This torque deflects the pointer attached to the drum. The controlling torque is provided by spring action.

PRINCIPLE:

When a disc or drum of a non-magnetic conducting material is placed in a rotating magnetic field, eddy currents are induced in disc or drum. The torque produces with the reaction of rotating magnetic field and eddy current. The relation between torque, eddy current, rotating flux is given below:

$$T \propto \phi \propto i^2$$

CONSTRUCTION:

This instrument consists of magnetic core (shaped same as transformer). One end is placed with band of copper (shaded portion), this makes the two fluxes of shaded and unshaded portion of differ in phase by 90.

*A metallic disc rotates between pole faces. The damping is provided by the another magnet. Observe below figure.

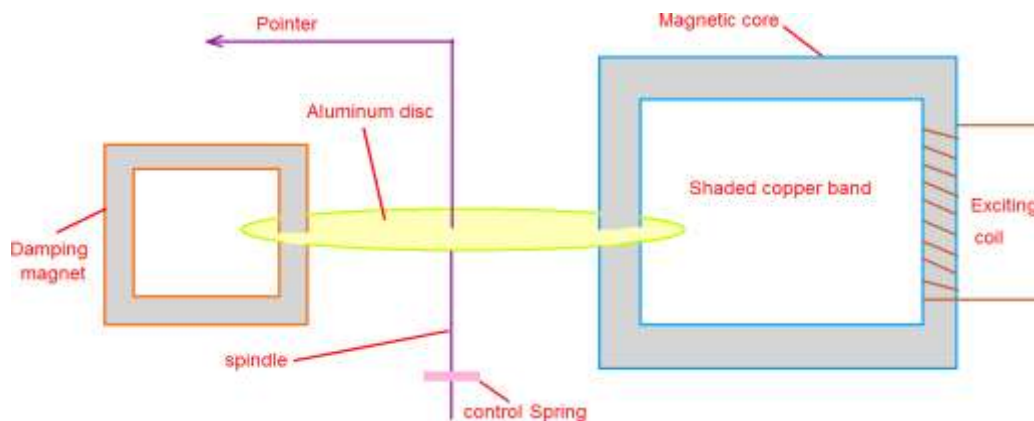

WORKING:

When the instrument is fed with the supply the coil sets up flux, eddy currents are induced in copper bands. Now there are two different fluxes one at coil and other at magnetic core. These two fluxes differ by a phase of 90. Flux of eddy current opposes the flux of magnetic core the remaining working is same as split phase.

ADVANTAGES –

- A full scale deflection of over 300 degrees can be obtained.
- Good damping.
- Less effect of stray magnetic fields as the operating fields are large.

DISADVANTAGES –

- Errors are caused due to changes in frequency and temperature.
- Non-uniform scale.
- Large power consumption and high cost.
- Can be used for AC only.

Extend the range of instruments by use of shunts and Multipliers:

Calculation of Voltmeter Multiplier:

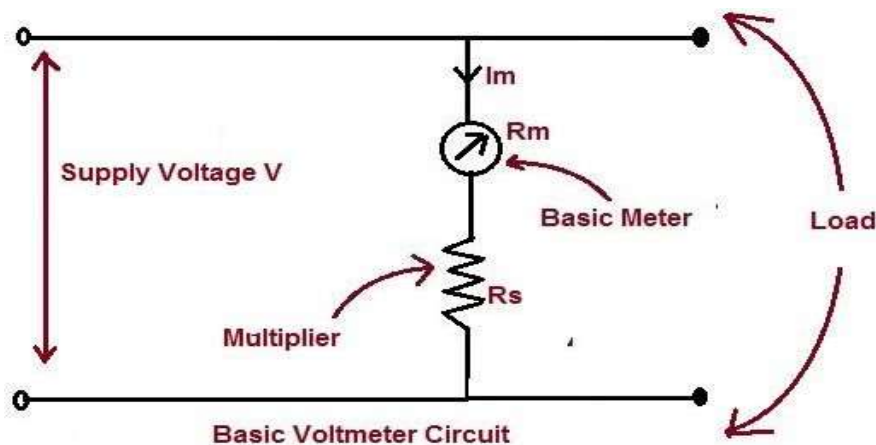

The value of multiplier required to extend the voltage range is calculated as below.

Let,

$I_m = I_{fs}$ = Full scale deflection current of meter

R_m = Internal resistance of meter

R_s = Multiplier resistance

V_m = Voltage across the moving coil

V = Full range voltage of meter

From the simplified voltmeter circuit given below,

$$V_m = I_m R_m \dots\dots\dots (1)$$

$$\text{and } V = I_m (R_m + R_s) \dots\dots\dots (2)$$

Dividing equation (2) by (1) we get,

$$V/V_m = 1 + R_s/R_m$$

Thus,

$$m = \text{Multiplying Factor} = 1 + R_s/R_m$$

Calculation of Ammeter Multiplier:

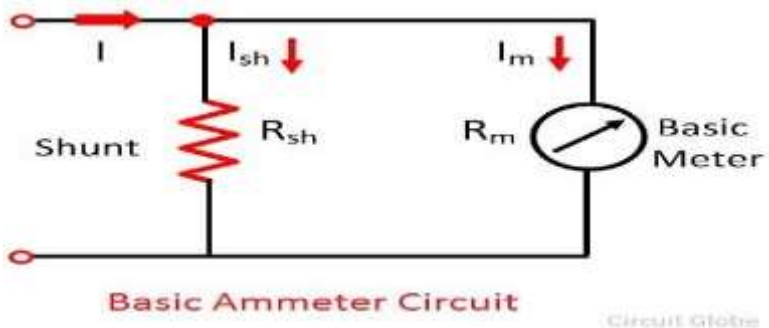

As the shunt connects in parallel with the ammeter, thus the same voltage drop occurs between them.

$$I_{sh} R_{sh} = I_m R_m$$

$$R_{sh} = \frac{I_m R_m}{I_{sh}}$$

The shunt current is

$$I_{sh} = I - I_m$$

Therefore the equation of shunt resistance is given as,

$$R_{sh} = \frac{I_m R_m}{I - I_m}$$

$$\frac{I}{I_m} - 1 = \frac{R_m}{R_{sh}}$$

$$\frac{I}{I_m} = 1 + \frac{R_m}{R_{sh}}$$

The ratio of the total current to the current requires the movement of the ammeter coil is called the multiplying power of the shunt.

The multiplying power is given as,

$$m = \frac{I}{I_m}$$

The resistance of shunt becomes,

$$m = 1 + \frac{R_m}{R_{sh}}$$

$$R_{sh} = \frac{R_m}{m - 1}$$

.....

UNIT-3

WATTMETERS AND MEASUREMENT OF POWER

Wattmeter

An instrument for measuring the power of an electrical current in watts. The most common wattmeters are the dynamometer type, in which the mechanism consists of an immovable coil connected in series to a load and then to a movable coil, which is connected through a large auxiliary resistor parallel to the load.

Construction, principle of working of Dynamometer type wattmeter

Construction:

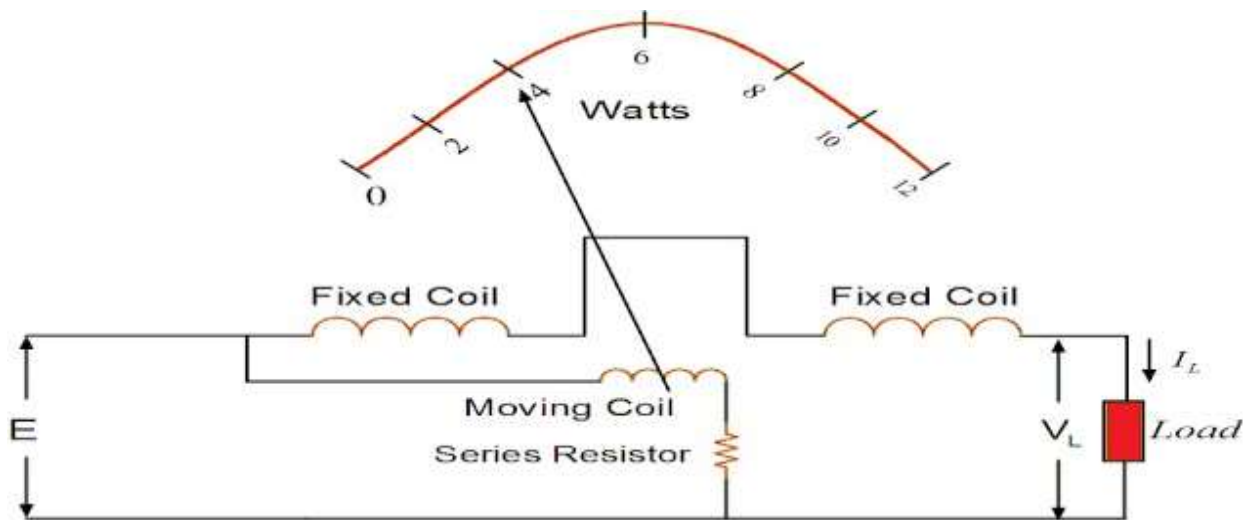

A dynamometer type wattmeter primarily consists of two coils called fixed coil and moving coil. The fixed coil is splitted into two equal parts, which are placed parallel to each other. The two fixed coils are air-cored to avoid hysteresis effects when used on AC.

The fixed coil is connected in series with the load and carries the circuit current. It is, therefore, called the current coil. The moving coil is pivoted between the two parts of the fixed coil and is mounted on a spindle.

A pointer is attached to the spindle, which gives deflection. The moving coil is connected in parallel with the load and carries the current proportional to the voltage. It is, therefore, called the potential coil.

Generally, a high resistance is connected in series with the moving coil to limit the current through it. By limiting the current, the moving coil is made lightweight, which in turn increases the sensitivity of the instrument.

The springs provide the controlling torque. They also serve the additional purpose of leading the current into and out of the moving coil. Air friction damping is employed in such instruments.

Working

We use the wattmeter for power measurements. Its current coil is connected in series with the load, carries the load current, and the potential coil, connected in parallel with the load, carries the current proportional to the voltage across the load.

The fixed coil produces a field F_m , and moving coil creates a field F_r . The field F_r tries to come in line with the main field F_m , which provides a deflecting torque on the moving coil. Thus, the pointer attached to the spindle of the moving coil deflects. This deflection is controlled by the controlling torque produced by the springs.

Advantages:

- It can be used both on AC and DC circuits.
- It has a uniform scale.
- We can obtain a high degree of accuracy through careful design.

Disadvantages:

- At low power factors, the inductance of the potential coil causes serious errors.
- The reading of the instrument may be affected by stray fields acting on the moving coil. To prevent it, magnetic shielding is provided by enclosing the instrument in an iron case.

Errors in Dynamometer type wattmeter and methods of their correction

1. Error due to potential coil inductance: The inductance of the potential coil is liable to cause an error in the reading of the wattmeter. Because of this error, the wattmeter gives a high reading on lagging power factor and low reading on leading power factor.

The high non-inductive resistance connected in series with the coil swamps the phasing effect of the potential coil inductance.

2. Error due to power loss in the potential coil or current coil: Another possible error in the indicated power may be due to some voltage drop in the current coil or the current taken by the potential coil.

We can overcome this defect by using an additional compensating winding. This winding is connected in series with the potential coil and so placed that it produces a field in the opposite direction to that of the current coils.

3. Error due to eddy currents: The alternating field of fixed or current coil induces eddy currents in the solid metal parts which set up their own magnetic field. This alters the magnitude and phase of the magnetic field, causing deflection.

Thus an error is introduced in the instrument reading. To reduce this error, the solid metal parts are placed far away from the current coil as possible.

4. Error due to the stray magnetic field: The dynamometer type wattmeter has a relatively weak operating field; therefore, stray fields affect the reading of this instrument considerably and cause serious errors.

Hence, this type of instrument must be shielded against stray magnetic fields by using iron cases or providing thin iron shields over the working parts.

Induction type wattmeter:

Construction

The principle parts of an induction wattmeter is as shown in the fig below. It consists of two laminated electromagnets. One electromagnet, called shunt magnet is connected across supply and carries current proportional to the applied voltage. The coil of this magnet is made highly inductive so that the current in it lags behind the supply voltage by 90 degrees. The other electromagnet, called series magnet is connected in series with supply and carries the load current.

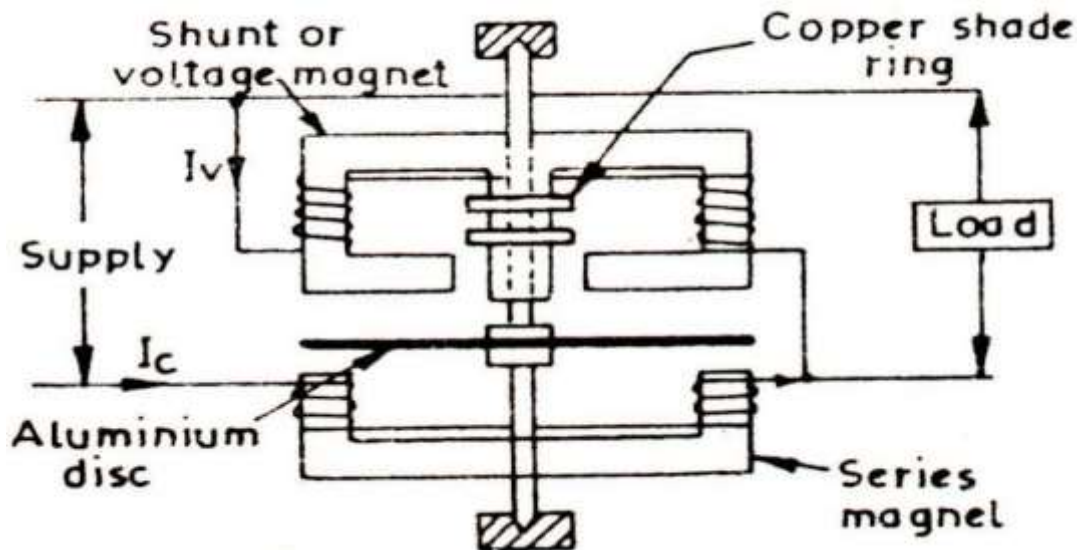

A thin aluminum disc mounted on the spindle is placed in between the two magnets so that it cuts the fluxes of both the magnets. The controlling torque is provided by spiral springs. The damping is electromagnetic and is usually provided by a permanent magnet embracing the aluminum disc. Two or more closed copper rings, called shading rings are provided on the central limb of the shunt magnet. By adjusting the position of these rings, the shunt magnet flux can be made to lag behind supply voltage by exactly 90 degrees.

Working

When the wattmeter is connected in the circuit to measure a.c power, the shunt magnet carries current proportional to the supply voltage and the series magnet carries the load current. The two fluxes produced by the magnets induce eddy currents in the aluminum disc. The interaction between the fluxes and eddy currents produce the deflecting torque on the disc, causing the pointer connected to the moving system to move over the scale.

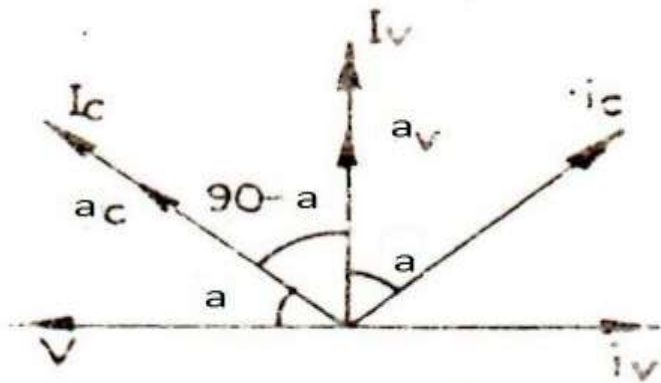

Deflecting torque of Induction type wattmeter:

Let V = Applied voltage

I_c = Load current carried by the series magnet

I_v = Current carries by the shunt magnet

$\cos a$ = Lagging power factor of the load

Mean deflecting torque, T_d proportional $ac \sin (90 - a)$

T_d proportional $V I \cos a$

T_d proportional a.c power

Since control is by springs, therefore

T_c proportional deflection

For steady deflected position, $T_d = T_c$

Deflection proportional power

Hence, such instruments have uniform scale

.....

UNIT-4

ENERGYMETERS AND MEASUREMENT OF ENERGY

Definition: The meter which is used for measuring the energy utilized by the electric load is known as the energy meter. The energy is the total power consumed and utilized by the load at a particular interval of time. It is used in domestic and industrial AC circuit for measuring the power consumption. The meter is less expensive and accurate.

Single Phase Induction type Energy meters

To understand the structure of watt-hour meter, we must understand the four essential components of the meter. These components are as follows:

1. Driving system
2. Moving system
3. Braking system
4. Registering system

Driving System

The components of this system are two silicon steel laminated electromagnets. The upper electromagnet is called shunt magnet and it carries a voltage coil consisting of many turns of thin wire. The lower electromagnet is called series magnet and it carries the two current coils consisting of a few turns of thick wire. Current coils are connected in series with the circuit and load current passes through it.

Moving System

As you can see in the figure, there is a thin aluminum disk placed in the gap between the two electromagnets and mounted on a vertical shaft. The eddy currents are induced in the aluminum disk when it cuts the flux produced by both the magnets. As a result of interference of eddy currents and two magnetic fields constitute a deflecting torque in the disk.

Braking System

The main part of this system is a permanent magnet called brake magnet. It is located near the disk so that eddy currents are induced in it due to movement of rotating disk through the magnetic field. This eddy current reacts with the flux and exerts a braking torque which opposes the motion of the disk. The speed of the disk can be controlled by changing flux.

Registering System

As its name suggest, it registers the number of rotation of the disk which is proportional to the energy consumed directly in kilowatt-hour. There is a disk spindle which is driven by a gear on the disk shaft and indicates the number of times the disk has turned.

Working Principle of Energy Meter

The working of single phase induction type energy meters are based on two main fundamentals:

1. Rotation of aluminum disk.
2. Arrangement of counting and displaying the amount of energy consumed.

Rotation of an Aluminum Disk

The rotation of metallic disk is operated by two coils. Both the coils are arranged in such way that one coil produces a magnetic field in proportion to voltage and the other coil creates a magnetic field proportion to current. The field produced by voltage coil is delayed by 90° so that eddy current is induced in the disk. The force exerted on the disk by the two fields is proportional to the product of the immediate current and voltage in the coils.

As a result of it, a lite weight aluminum disk rotates in an air gap. But there is a need to stop a disk when there is no power supply. A permanent magnet works as a brake which opposes the rotation of the disk and balances the speed of rotation with respect to power consumption.

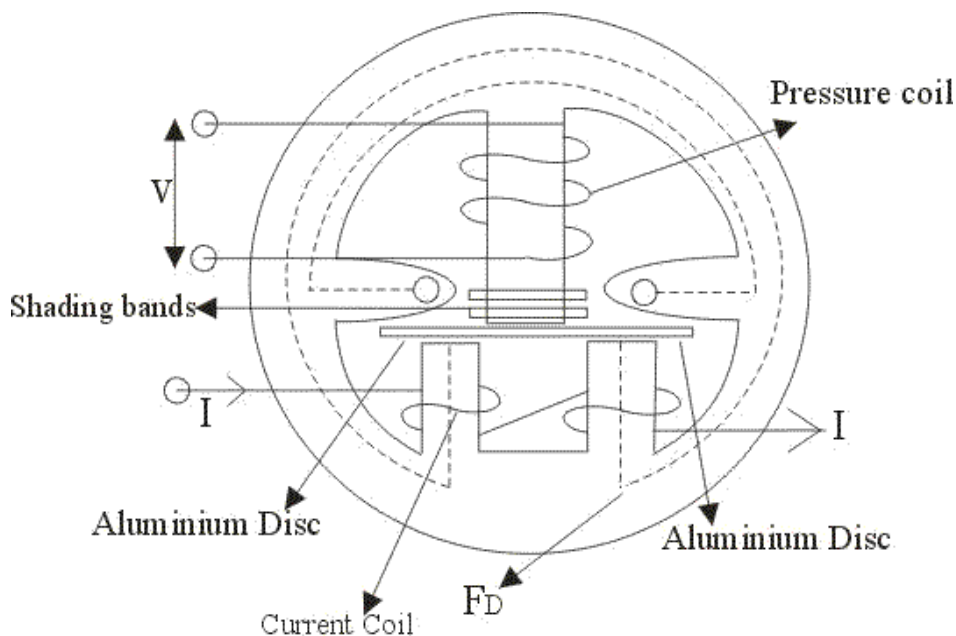

Arrangement of Counting and Displaying the Energy Consumed

In this system, the rotation of the floating disk has been counted and then displayed on the meter window. The aluminum disk is connected to a spindle which has a gear. This gear drives the register and the revolution of the disk has been counted and displayed on the register which has series of dials and each dial represent a single digit.

Tests for Energy Meters

1. Mechanical component tests.
2. Climatic conditions test include those limits which influence the performance of the meter externally.

Electrical requirements covered many tests before giving accuracy certificate. Under this segment, energy meter is tested for:

1. Heating effect
 2. Proper insulation
 3. Supply of voltage
 4. Protection to earth fault
 5. Electromagnetic compatibility
-

UNIT-5

MEASUREMENT OF SPEED, FREQUENCY AND POWER FACTOR

Tachometers types and working principles:-

Definition: The tachometer use for measuring the rotational speed or angular velocity of the machine which is coupled to it. It works on the principle of relative motion between the magnetic field and shaft of the coupled device. The relative motion induces the EMF in the coil which is placed between the constant magnetic field of the permanent magnet. The develops EMF is directly proportional to the speed of the shaft.

Mechanical and electrical are the two types of the tachometer. The mechanical tachometer measures the speed of shaft regarding revolution per minutes.

The electrical tachometer converts the angular velocity into an electrical voltage. The electrical tachometer has more advantages over the mechanical tachometer. Thus it is mostly used for measuring the rotational speed of the shaft. Depends on the natures of the induced voltage the electrical tachometer is categorized into two types.

1. AC Tachometer Generator
2. DC Tachometer Generator

DC Tachometer Generator

Permanent magnet, armature, commutator, brushes, variable resistor, and the moving coil voltmeter are the main parts of the DC tachometer generator. The machine whose speed is to be measured is coupled with the shaft of the DC tachometer generator.

The DC tachometer works on the principle that when the closed conductor moves in the magnetic field, EMF induces in the conductor. The magnitude of the induces emf depends on the flux link with the conductor and the speed of the shaft.

The armature of the DC generator revolves between the constant field of the permanent magnet. The rotation induces the emf in the coil. The magnitude of the induced emf is proportional to the shaft speed.

The commutator converts the alternating current of the armature coil to the direct current with the help of the brushes. The moving coil voltmeter measures the induced emf. The polarity of the induces voltage determines the direction of motion of the shaft. The resistance is connected in series with the voltmeter for controlling the heavy current of the armature.

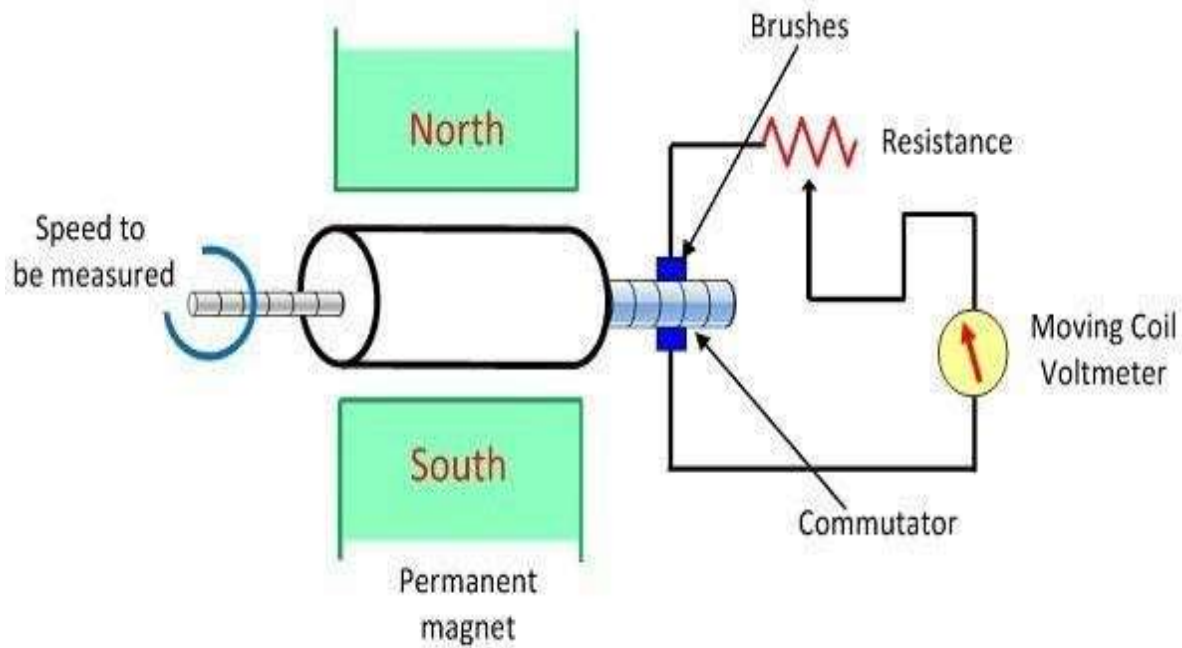

DC Tachometer Generator

Circuit Globe

The emf induces in the dc tachometer generator is given as

$$E = \frac{\Phi P N}{60} \times \frac{z}{a}$$

Where,

E – Generated voltage

Φ – flux per poles in Weber

P- number of poles

N – speed in revolution per minutes

Z – the number of the conductor in armature windings.

a – number of the parallel path in the armature windings.

$$E \propto N$$

$$E = KN$$

$$K = \text{Constant} = \frac{\Phi P}{60} \times \frac{z}{a}$$

The following are the **Advantages** of the DC Tachometer.

- The polarity of the induced voltages indicates the direction of rotation of the shaft.
- The conventional DC type voltmeter is used for measuring the induced voltage.

Disadvantages of DC Generator

- The commutator and brushes require the periodic maintenance.
- The output resistance of the DC tachometer is kept high as compared to the input resistance. If the large current is induced in the armature conductor, the constant field of the permanent magnet will be distorted.

AC Tachometer Generator

The DC tachometer generator uses the commutator and brushes which have many disadvantages. The AC tachometer generator designs for reducing the problems. The AC tachometer has stationary armature and rotating magnetic field. Thus, the commutator and brushes are absent in AC tachometer generator.

The rotating magnetic field induces the EMF in the stationary coil of the stator. The amplitude and frequency of the induced emf are equivalent to the speed of the shaft. Thus, either amplitude or frequency is used for measuring the angular velocity.

The below mentioned circuit is used for measuring the speed of the rotor by considering the amplitude of the induced voltage. The induced voltages are rectified and then pass to the capacitor filter for smoothing the ripples of rectified voltages.

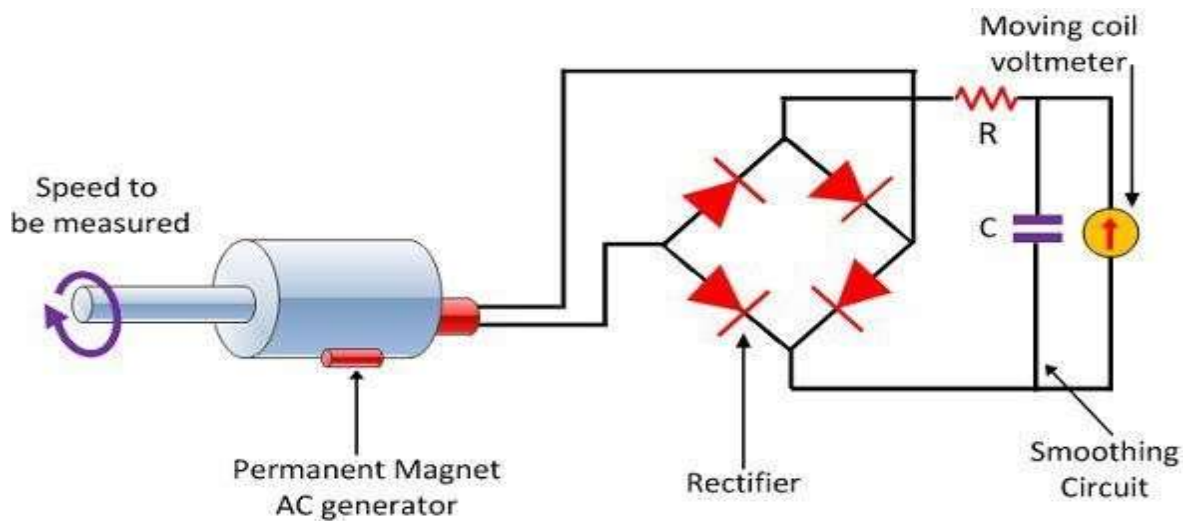

A.C Tachometer Generator

Circuit Globe

Drag Cup Rotor AC Generator

The drag cup type A.C tachometer is shown in the figure below.

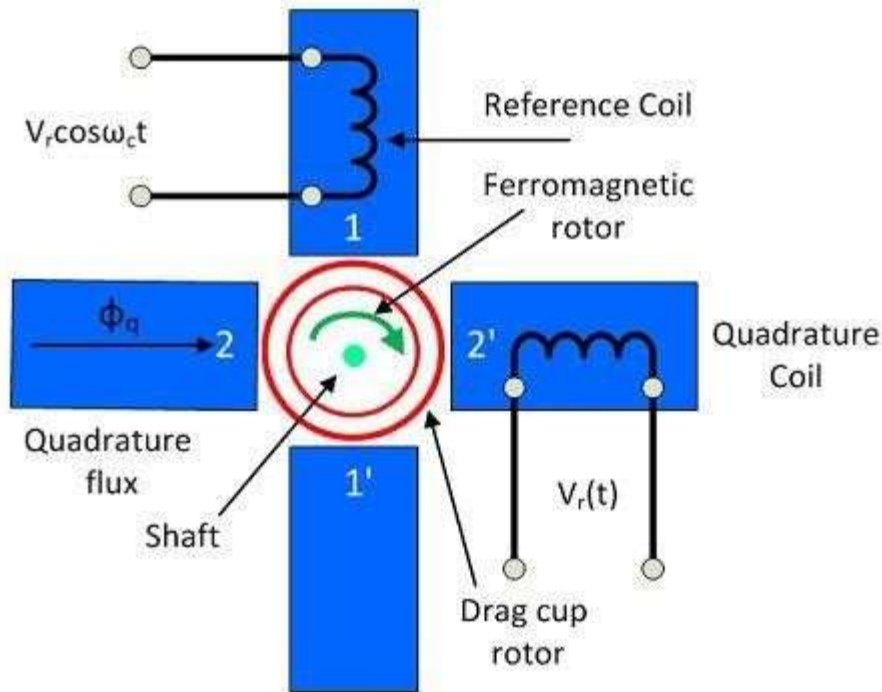

A.C Tachometer Generator

Circuit Globe

The stator of the generator consists two windings, i.e., the reference and quadrature winding. Both the windings are mounted 90° apart from each other. The rotor of the tachometer is made with thin aluminum cup, and it is placed between the field structure.

The rotor is made of the highly inductive material which has low inertia. The input is provided to the reference winding, and the output is obtained from the quadrature winding. The rotation of rotor between the magnetic field induces the voltage in the sensing winding. The induced voltage is proportional to the speed of the rotation.

Advantages

- ✓ The drag cup Tachogenerator generates the ripple free output voltage.
- ✓ The cost of the generator is also very less.

Disadvantage

The nonlinear relationship obtains between the output voltage and input speed when the rotor rotates at high speed.

Mechanical Resonance Type Frequency Meter

The vibrating reed type frequency meters or mechanical resonance type frequency meter indicate the supply frequency of the circuit directly and are very much convenient for most practical purposes.

The vibrating reed frequency meter is a very simple instrument and has got an advantage of giving reading free from errors due to change in temperature, waveform and magnitude of applied voltage.

Construction

A vibrating reed frequency meter consists of a number of thin steel strips called reeds. These reeds are placed in a row alongside and close to an electromagnet. The electromagnet consists of thin laminations and a coil is wound around it as shown in fig. The coil is connected in series with a resistance across the supply whose frequency is to be measured.

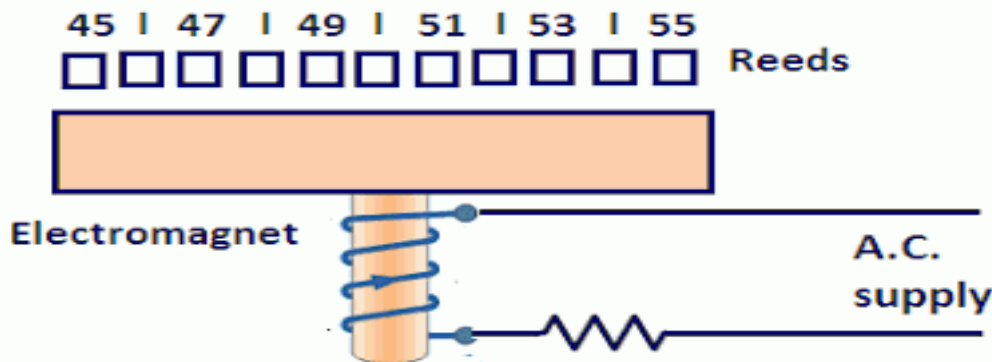

Viberating reed type frequency meter

Vibrating reed mechanical resonance type frequency meter working and construction. The approximate dimensions of the vibrating reeds are about 4 mm wide and $\frac{1}{2}$ mm thick. The reeds are not similar to each other but differ either in their dimensions or weight or carry different flags at their tops. This is done to vary the natural frequency of vibration of each reed.

The reeds are arranged in ascending order of natural frequency the difference in frequency is usually 1Hz. Thus the natural frequency of first reed may be 45 Hz, of the second 46 Hz, of the next 47 Hz and so on of the last may be 55 Hz.

The reeds are fixed at the bottom end and are free at the top end. The flags at the top of reeds are - painted white, and the frequency is read directly from the instrument by observing the scale mark opposite to the reed which is vibrating most.

Working Principle

When the vibrating reed frequency meter or mechanical resonance type frequency meter is connected across the supply whose frequency is to be measured an alternating current I flows through the coil of an electromagnet which produces a force of attraction on the reeds. The force of attraction is proportional to the square of the current therefore it varies at twice the supply frequency. Hence a force is exerted on the reeds at every half cycle.

All the reeds thus tend to vibrate, but only the one whose natural frequency is double that of supply will vibrate appreciably. Mechanical resonance is obtained in the case of this reed. The frequency is determined, therefore by noting the scale reading opposite the reed that vibrates with maximum amplitude.

The tuning in these meters is so sharp that as the excitation frequency changes from resonant frequency the amplitude of vibration decreases rapidly becoming negligible for a frequency which is slightly away from resonant one.

Advantages of Vibrating Reed Type Frequency Meter

The indication of the frequency of an electrical signal does not depend on the pattern of the waveform of the signal.

The indication also does not depend on the magnitude of the signal waveform. Only it requires sufficiently large amplitude for visible reed vibration.

Disadvantage of Mechanical Resonance Frequency Meter

The instrument cannot indicate properly a frequency which is in between 0.5 precision.

Electrical Resonance Frequency Meter

Electrical resonance frequency meter is very simple instrument of indicating type. This instrument operates on the principle of electrical resonance, i.e. when inductive reactance (X_L) and capacitive reactance (X_C) become equal, electrical resonance is said to have occurred.

Construction

It consists of a fixed coil which is connected across the supply whose frequency is to be measured. Fixed coil is also called magnetizing coil. The magnetizing coil is mounted on a laminated iron core. The iron core has a cross-section which varies gradually over the length, being maximum near the end where the magnetizing coil is mounted and minimum at the other end. The moving coil is pivoted over this iron core. The pointer is attached to the moving coil. The capacitor is connected with moving coil.

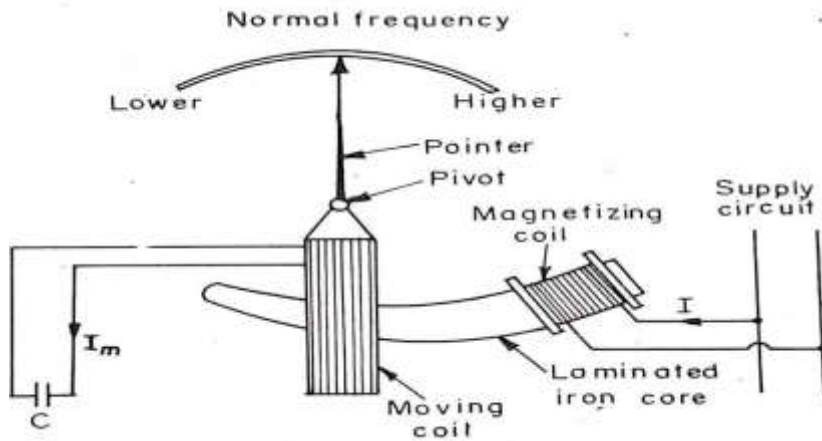

Working

When the magnetizing coil is connected across supply, the current I flows through the magnetizing coil and sets up flux Φ . If we neglect the resistance of the coil and iron losses in the core, flux Φ is phase with current I . Since flux Φ is an alternating flux, it will induce e.m.f. 'e' in the moving coil and current start flows.

The phase of this current depends upon the inductance L of the moving coil and the capacitance C .

The operation can be well explained with the help of phasor diagram;

In first case, the circuit of the moving coil assumed to be inductive and therefore current I lags behind the e.m.f. 'e' by an angle α . The deflecting torque acting on the moving coil is thus:

$$T_d = i \cos (90^\circ + \alpha)$$

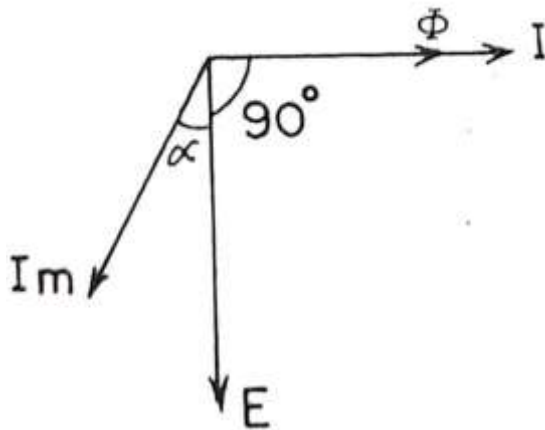

In second case, the moving coil is assumed to be largely capacitive therefore current 'i' lead the e.m.f. 'e' by an angle β and therefore the deflecting torque is thus:

$$T_d = i \cos(90^\circ - \beta)$$

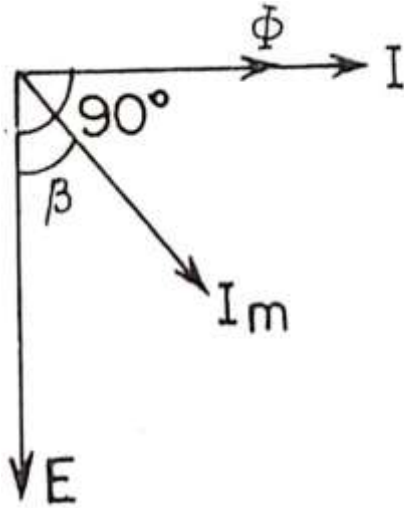

In third case, the inductive reactance is supposed to be equal to the capacitive reactance so that i is in phase with e and the torque upon the pivoted coil is proportional to $T_d = i \cos 90^\circ$ which is Zero.

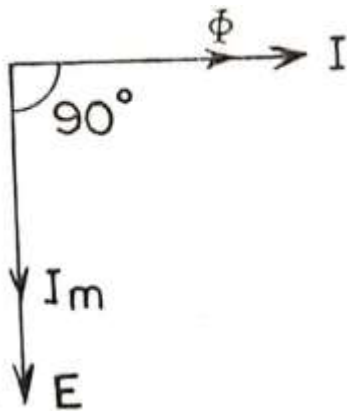

Coming to actual operation of the instrument for a fixed frequency is constant but the inductive reactance of the moving coil is not constant. The inductive reactance depends upon the position of the pivoted coil on the core. This inductance, hence inductive reactance is maximum when the moving coil occupies a position close to the magnetizing coil and minimum when it is at other end.

The value of capacitor 'C' is so selected that the moving coil occupies a convenient position in the Centre when the frequency is at its normal value. Under these conditions the inductive reactance becomes larger than the capacitive reactance. This is because the inductive reactance is directly proportional to the supply frequency and capacitive reactance is inversely proportional to the frequency. Thus the circuit becomes largely inductive and, therefore, there is a torque produced.

If the frequency decreases below the normal, value of the capacitive reactance becomes more than the inductive reactance and hence there is a torque produced.

power factor meters

Definition: The power factor meter measures the power factor of a transmission system. The power factor is the cosine of the angle between the voltage and current. The power factor meter determines the types of load using on the line, and it also calculates the losses occur on it.

Types of Power Factor Meter

The power factor meter is of two types.

They are

1. Electrodynamicometer

- ✓ Single Phase Electrodynamicometer
- ✓ Three Phases Electrodynamicometer

2. Moving Iron Type Meter

- ✓ Rotating Iron Magnetic Field
- ✓ Number of Alternating Field

Single Phase Electrodynamicometer

The construction of the single phase electrodynamicometer is shown in the figure below. The meter has fixed coil which acts as a current coil. This coil is split into two parts and carries the current under test. The magnetic field of the coil is directly proportional to the current flow through the coil.

The meter has two identical pressure coils A and B. Both the coils are pivoted on the spindle. The pressure coil A has no inductive resistance connected in series with the circuit, and the coil B has highly inductive coil connected in series with the circuit.

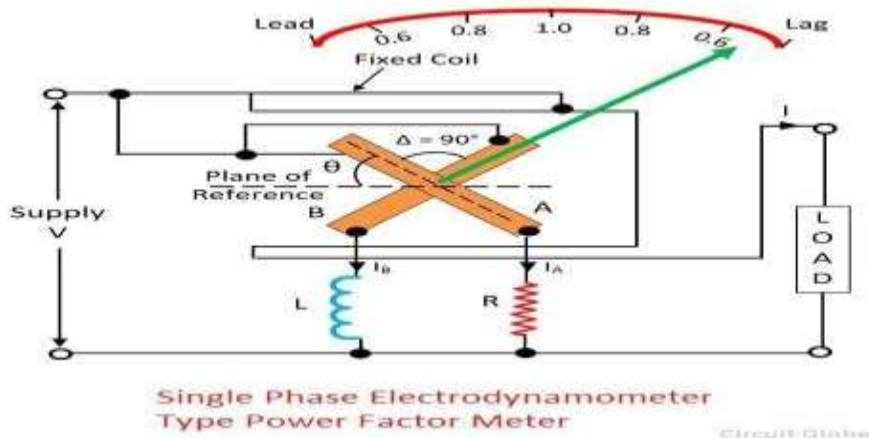

The current in the coil A is in phase with the circuit while the current in the coil B lag by the voltage nearly equal to 90° . The connection of the moving coil is made through silver or gold ligaments which minimize the controlling torque of the moving system.

The meter has two deflecting torque one acting on the coil A, and the other is on coil B. The windings are so arranged that they are opposite in directions. The pointer is in equilibrium when the torques are equal.

Deflecting torque acting on the coil A is given

$$T_A = KVIM \cos \phi \sin \theta$$

θ – Angular deflection from the plane of reference.

M_{max} – maximum value of mutual inductance between the coils.

The deflecting torque acting on coil B is expressed as

$$I_B = KVIM_{max} \cos(90^\circ - \phi) \sin(90^\circ + \phi)$$

$$I_B = KVIM_{max} \cos \phi \sin \theta$$

The deflecting torque is acting on the clockwise direction.

The value of maximum mutual inductance is same between both the deflecting equations.

$$T_A = T_B$$

$$KVIM \cos \phi \sin \theta = KVIM_{max} \cos \phi \sin \theta$$

This torque acts on anti-clockwise direction. The above equation shows that the deflecting torque is equal to the phase angle of the circuit.

Three Phase Electrodynamic Power Factor Meter

The construction of the three phase meter is shown in the figure below. The electrodynamic meter is only useful for the balanced load. The moving coil is placed at an angle of 120° . They are connected across different phases of the supply circuit. Both the coil has a series resistance.

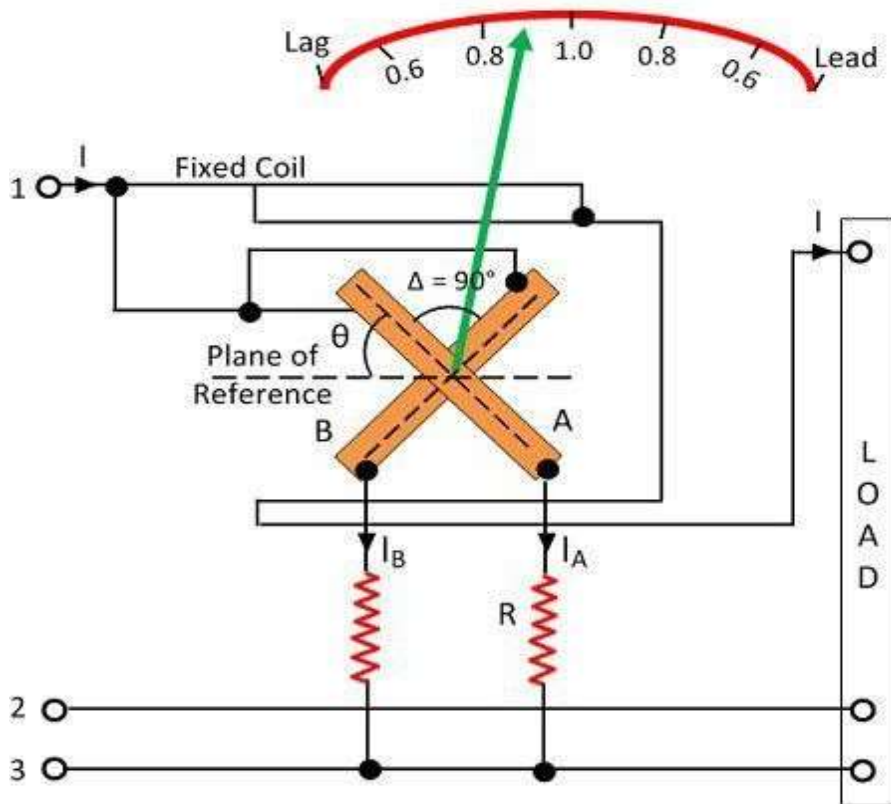

Three Phase Dynamo Type Factor Meter

Circuit Globe

The voltage across the coil A is V_{12} and the current across it I_{A1} . The circuit of the coil is resistive, and hence the current and voltage are in phase with each other. Similarly, the voltage V_{13} and the current I_{B1} is in phase with each other. The phasor diagram of the three phase electrodynamic meter is shown in the figure below.

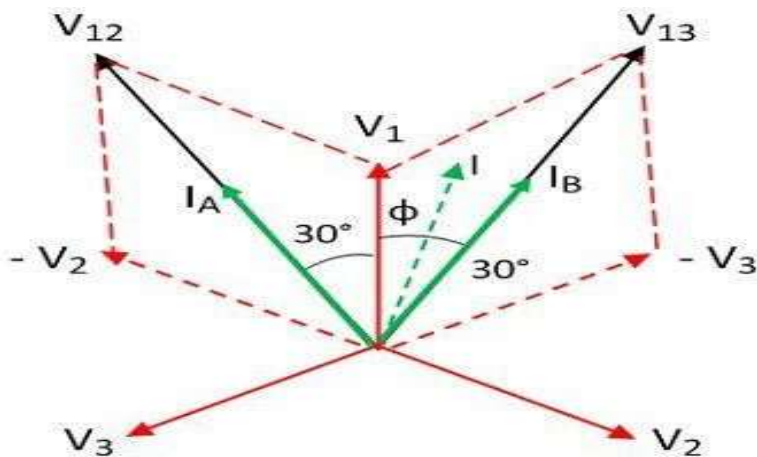

Phasor Diagram of Three Phase Electrodynamic Meter Type Power Factor Meter

Circuit Globe

Let Φ – phase angle of the circuit.

θ – angular deflection from the plane of reference.

Torque acting on coil A is

$$T_A = KVI_{12}M_{max} \cos(30^\circ + \phi) \sin(60^\circ + \phi)$$

$$T_A = \sqrt{3}KVI_{12}M_{max} \cos(30^\circ + \phi) \sin(60^\circ + \phi)$$

Torque acting on coil B is

$$T_B = KVI_{12}M_{max} \cos(30^\circ - \phi) \sin(120^\circ + \phi)$$

$$T_B = KVI_{12}M_{max} \cos(30^\circ - \phi) \sin(120^\circ + \phi)$$

The torque T_A and T_B are acting on the opposite directions.

$$\cos(30^\circ - \phi) \sin(120^\circ + \phi) = \cos(30^\circ - \phi) \sin(120^\circ + \phi)$$

Thus the angular deflection of the coil is directly proportional to the phase angle of the circuit.

Advantages of Electrodynamic Type Power Factor Meters

- ✓ Losses are less because of minimum use of iron parts and also give less error over a small range of frequency as compared to moving iron type instruments.
- ✓ They high torque is to weight ratio.

Disadvantages of Electrodynamic Type Power Factor Meters

- ✓ Working forces are small as compared to moving iron type instruments.
- ✓ The scale is not extended over 360°.
- ✓ Calibration of electrodynamic type instruments are highly affected by the changing the supply voltage frequency.
- ✓ They are quite costly as compared to other instruments.

.....

UNIT-6

MEASUREMENT OF RESISTANCE, INDUCTANCE & CAPACITANCE

Classification of resistance:-

We categorize the resistance into three classes-

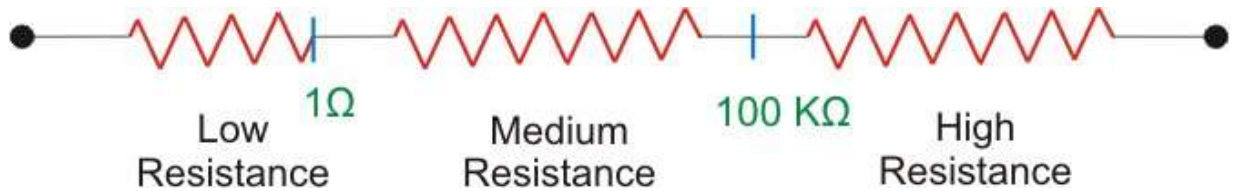

1. Measurement of Low Resistance ($<1\Omega$)
2. Measurement of Medium Resistance ($1\Omega - 100\text{k}\Omega$)
3. Measurement of High Resistance ($>100\text{k}\Omega$)

Measurement of low resistance by potentiometer method:-

The DC potentiometer method of measurement of resistance is used for measuring the unknown resistance of low value. This can be done by comparing the unknown resistance with the standard resistance. The voltage drop across the known and unknown resistance is measured and by comparison the value of known resistance is determined.

Let understand this with the help of the circuit diagram. The R is the unknown resistance whose value is needed to be measured. The S is the standard resistance from which the value of unknown resistance is compared. The rheostat is used for controlling the magnitude of current into the circuit.

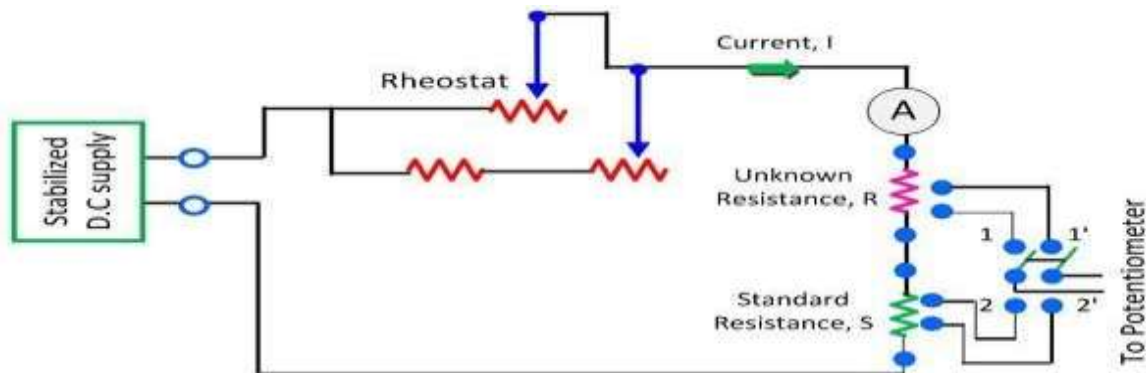

Measurement of Resistance with Potentiometer

Circuit Globe

The double pole double throw switch is used in the circuit. The switch, when moves to position 1, 1 the unknown resistance connect to the circuit, and when it moves to position 2, 2 the standard resistance connects to the circuit.

Consider that when the switch is in position 1,1 the voltage drop across the unknown resistance is V_R

$$V_R = IR$$

And when it is in 2, 2 the voltage drop across the resistance is V_s .

$$V_S = IS$$

On equating the equation (1) and (2), we get

$$\frac{V_R}{V_S} = \frac{IR}{IS}$$

$$\frac{V_R}{V_S} = \frac{R}{S}$$

$$R = \frac{V_R}{V_S} \cdot S$$

The accuracy of unknown resistance depends on the value of standard resistance.

The accuracy of the unknown resistance also depends on the magnitude of the current at the time of the readings. If the magnitude of current remains same, the circuit gives the accurate result. The ammeter is used in the circuit for determining the magnitude of current passing through resistor during the reading.

The magnitude of the current is adjusted in such a way that the voltage drop across the resistance is equal to 1 volt.

Measurement of medium resistance by wheat Stone bridge method:-

Wheatstone bridge is a very important device used in the measurement of medium resistances.

The figure below shows the basic circuit of a Wheatstone bridge. It has four resistive arms, consisting of resistances P, Q R and S together with a source of emf (a battery) and a null detector, usually a galvanometer G or other sensitive current meter. The current through the galvanometer depends on the potential difference between point's c and d.

The bridge is said to be balanced when there is no current through the galvanometer or when the potential difference across galvanometer is zero. This occurs when the voltage from point b to point a equals the voltage from point d to point b or by referring to the other battery terminal when the voltage from point d to point c equals the voltage from point b to point c.

For a balanced condition, we can write,

$$I_1 P = I_2 R$$

The figure below shows the circuit for the Wheatstone bridge for the measurement of medium resistance.

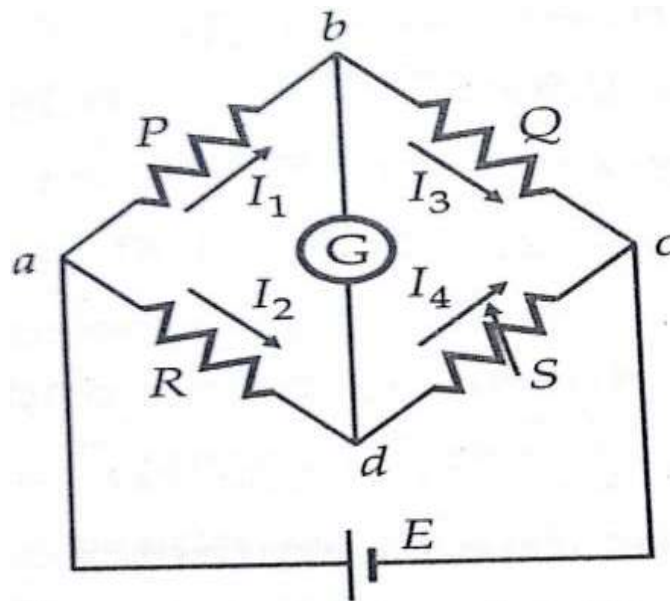

For the galvanometer current to be zero, the following conditions also exist:

$$I_1 = I_3 = \frac{E}{P+Q}$$

$$I_2 = I_4 = \frac{E}{R+S}$$

Where E = emf of the battery

Combining the above three equations we get,

$$\frac{P}{P+Q} = \frac{R}{R+S}$$

From which

$$Q.R = P.S \quad \text{--- (4)}$$

Equation-4 is the well-known expression for the balance of the Wheatstone bridge. If three of the resistances are known, the fourth may be determined from equation-4 and we obtain

$$R = S*(P/Q)$$

Where R is the unknown resistance, S is called the 'standard arm' of the bridge and P and Q are called the 'ratio arms'.

Measurement of high resistance by loss of charge method:-

In this method we utilize the equation of voltage across a discharging capacitor to find the value of unknown resistance r. Figure below shows the circuit diagram and the equations involved are-

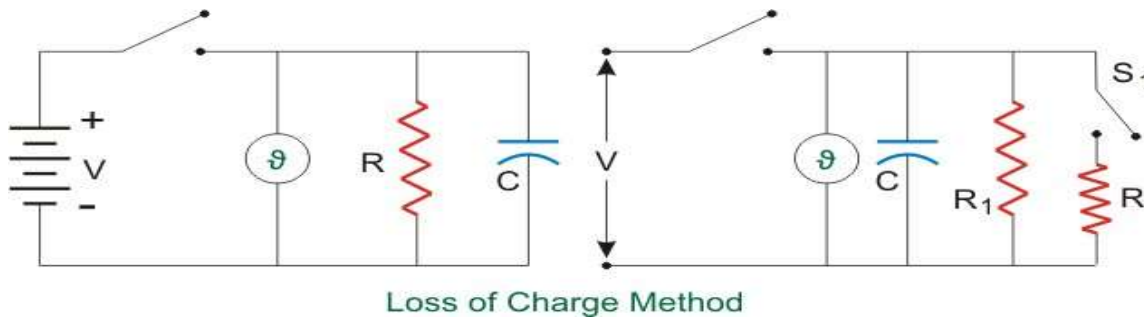

$$v = V e^{-\frac{t}{RC}}$$

$$R = \frac{0.4343t}{C \log_{10} V/v}$$

However the above case assumes no leakage resistance of the capacitor. Hence to account for it we use the circuit shown in the figure below. R_1 is the leakage resistance of C and R is the unknown resistance. We follow the same procedure but first with switch S_1 closed and next with switch S_1 open. For the first case we get

$$R' = \frac{0.4343t}{C \log_{10} V/v}$$

Where, $R' = \frac{RR_1}{R + R_1}$

For second case with switch open we get

$$R_1 = \frac{0.4343t}{C \log_{10} V/v}$$

Using R_1 from above equation in equation for R' we can find R .

Construction, principle of operations of Megger:-

Definition: The Megger is the instrument uses for measuring the resistance of the insulation. It works on the principle of comparison, i.e., the resistance of the insulation is compared with the known value of resistance. If the resistance of the insulation is high, the pointer of the moving coil deflects towards the infinity, and if it is low, then the pointer indicates zero resistance. The accuracy of the Megger is high as compared to other instruments.

Construction of Megger

The construction of the Megger is shown in the figure below. The Megger has one current coil and the two voltage coils V_1 and V_2 . The voltage coil V_1 is passed over the magnet connected to the generator. When the pointer of the PMMC instrument deflects towards infinity, it means that the voltage coil remains in the weak magnetic field and thus experienced the very little torque.

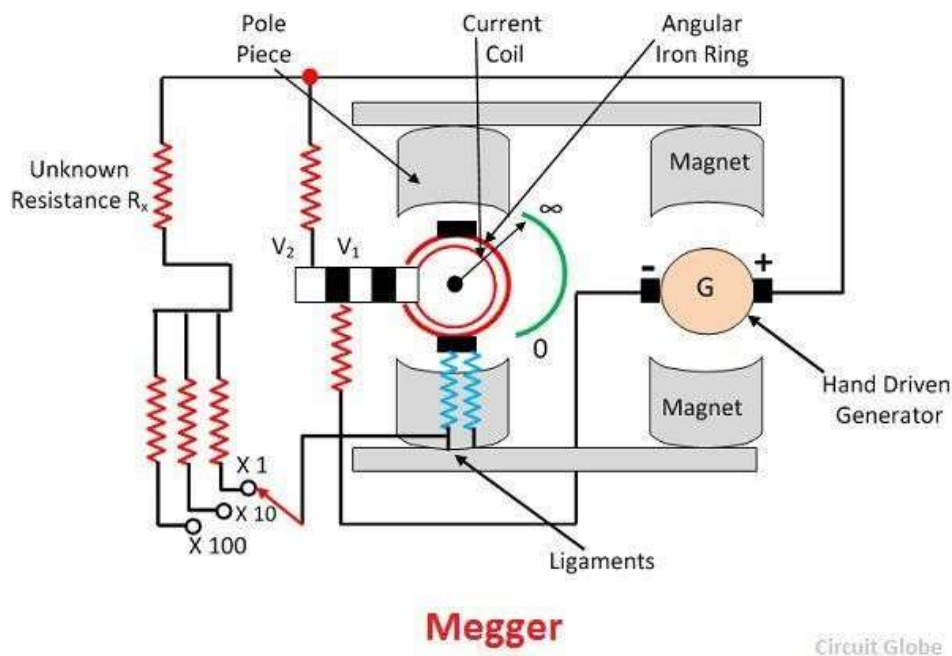

Working of Megger

- ✓ The testing voltage is usually 500, 1000 or 2500 V which is generated by the hand driven generator. The generator has centrifugal clutch due to which the generator supplied the constant for the insulation test. The constant voltage is used for testing the insulation having low resistance.

- ✓ The Megger has three coils two pressure coils and one current coil. The pressure coil rotates the moving coil in the anticlockwise direction, whereas the current coil rotates it in the clockwise direction.
- ✓ When the unknown resistance is connected in the circuit, the pointer of the moving coil becomes stable. The pressure coil and the current coil balance the pointer and set it in the middle of the scale.
- ✓ The deflection of the pointer is directly proportional to the voltage applied to the external circuit. When the testing circuit is applied across the Megger, and if there is no shorting throughout the insulation then the pointer deflects towards the infinity. Which shows that the resistance has high insulation. For low resistance, the pointer moves towards zero.

Earth Tester:-

Definition: The instrument used for measuring the resistance of the earth is known as earth tester. All the equipment of the power system is connected to the earth through the earth electrode. The earth protects the equipment and personnel from the fault current. The resistance of the earth is very low. The fault current through the earth electrode passes to the earth. Thus, protects the system from damage.

Construction and working of Earth Tester

- ✓ The earth tester uses the hand driven generator. The rotational current reverser and the rectifier are the two main parts of the earth tester. The current reverser and the rectifier are mounted on the shaft of the DC generator. The earth tester works only on the DC because of the rectifier.

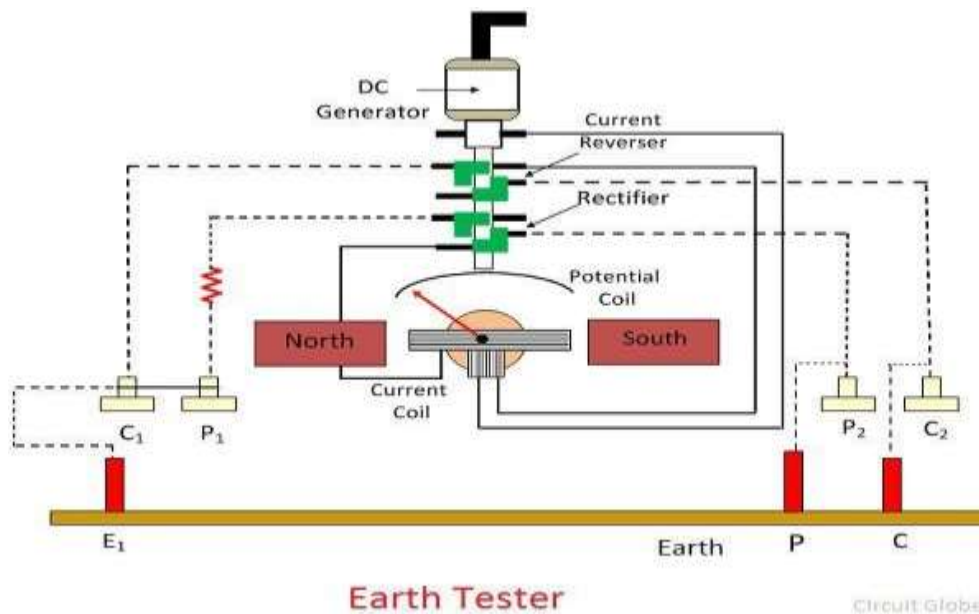

- ✓
- ✓ The tester has two commutators placed along with the current reverser and rectifier. Each commutator consists of four fixed brushes. The commutator is a device used for converting the direction of flow of current. It is connected in series with the armature of the generator.

And the brushes are used for transferring the power from the stationary parts to the moving parts of the devices.

- ✓ The earth tester consists two pressures and the current coils. The each coil has two terminals. The pair of the pressure coil and the current coil are placed across the permanent magnet. The one pair of current and pressure coil is short-circuited, and it is connected to the auxiliary electrodes.
- ✓ The one end terminal of the pressure coil is connected to the rectifier, and their other end is connected to the earth electrode. Similarly, the current coil is connected to the rectifier and earth electrode.
- ✓ The potential coil is placed between the permanent magnet. The coil is connected to the pointer, and the pointer is fixed on the calibrated scale. The pointer indicates the magnitude of the earth resistance. The deflection of the pointer depends on the ratio of the voltage of pressure coil to the current of the current coil.
- ✓ The short-circuit current passes through the equipment to the earth is alternating in nature. Thus, we can say that the alternating current flows in the soil.

Multimeter

A multimeter is the most commonly used instrument by technicians and engineers in the laboratory, as well as other repair works. As it is clear from the name of this instrument, it can make many (multi) measurements with reasonable accuracies such as AC and DC voltages, currents, and resistances. In this article, I am discussing the multimeter working principle.

Analog Multimeter Working Principle and Construction

A multimeter is a permanent magnet moving coil galvanometer. There is an iron cored coil pivoted on two jeweled bearings. The coil is wound on an aluminum former or bobbin. And this coil is free to rotate in the field of a permanent magnet. An aluminum pointer is attached to the coil and bobbin assembly and moves on a graduated scale.

There are two spiral springs attached to the coil assembly at the top and bottom, which provide a path for the flow of current and controlling torque.

A multimeter can measure voltage, current, and resistance for which its galvanometer is converted to a voltmeter, ammeter, and ohmmeter with the help of suitable circuits incorporated in it. The galvanometer used in a multimeter has always its pointer resting at zero position on the extreme left end various measurements are made on a multimeter as explained below:

Voltage Measurement by Multimeter

Generally, a galvanometer has a current sensitivity of the order of 0.1 mA and a small internal resistance of about 500 ohms. As such, it cannot measure high voltages. To measure high voltages,

its range is extended by connecting a high resistance in series with the galvanometer as shown in the figure.

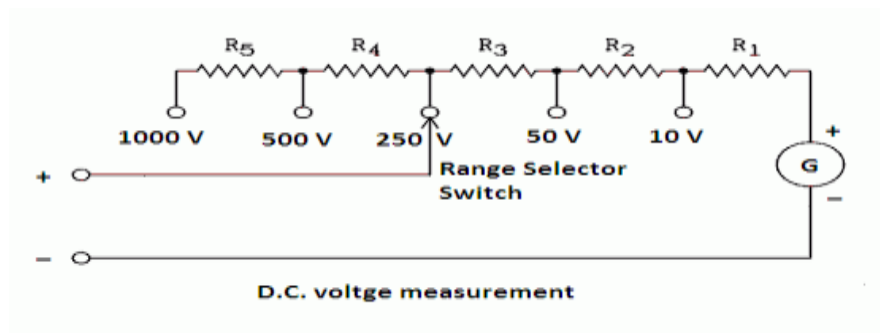

If the galvanometer resistance is denoted by G and I_g is the full-scale deflection current and the voltage to be measured is V volts, then the value of series resistance R_s is determined as under,

$$V = I_g R_s + I_g G$$

$$\text{Or } R_s = (V - I_g G) / I_g$$

This series resistance is also called the multiplier. The voltage range can be increased by increasing the number or value of multipliers. Either a selector switch is provided to select different ranges or some sockets indicating the voltage range are provided in a multimeter.

While making measurement one lead is inserted in the common socket and the other lead in the required voltage range socket.

The multimeter can also measure AC. For this purpose, a full-wave rectifier is incorporated in the multimeter. The rectifier converts AC into DC for application to the galvanometer.

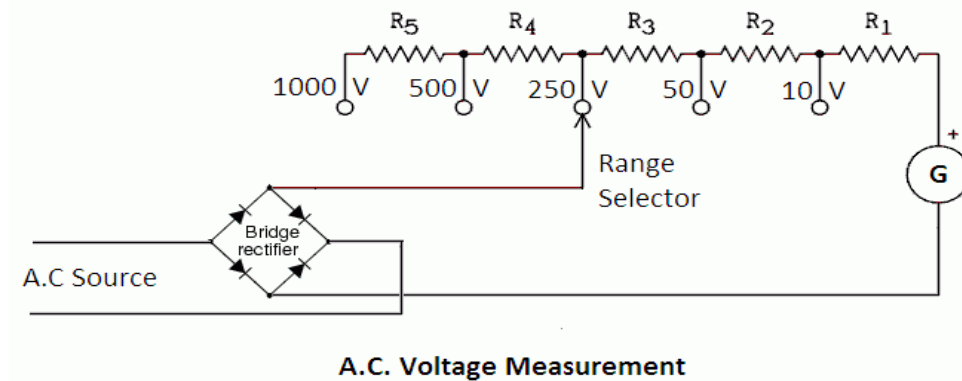

The desired AC voltage range is selected by the selector switch or sockets. When AC voltage is to be measured.

Current Measurement by Multimeter

The same galvanometer can be used for measuring current when it is converted into an ammeter by connecting a small resistance R_{sh} in parallel with the meter, as shown in the figure.

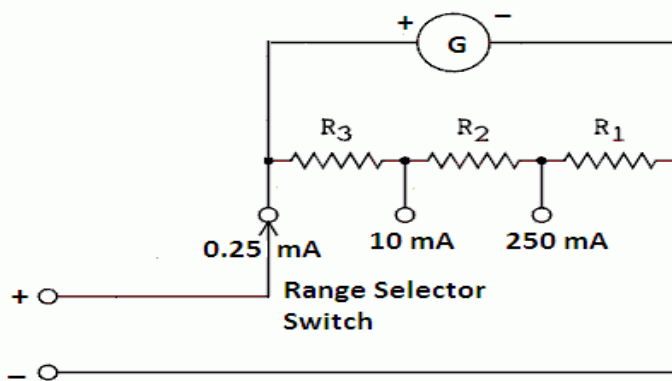

D.C. Current measurement by multimeter

If G is the internal resistance of meter, I_g its full-scale deflection current and I is the total current to be measured, then the value of shunt resistance R_{sh} required can be found as under:

$$(I - I_g)R_{sh} = I_g G$$

$$\text{Or } R_{sh} = I_g G / (I - I_g)$$

The range of ammeter can be extended to any value within limits by reducing the value of shunt resistance. Some low resistances are connected in parallel with the meter through a selector switch, as shown in the figure. The desired range can be selected by moving the selector switch to a particular position.

If the total current to be measured, I is very high, the value of shunt resistance required R_{sh} becomes very low, which is sometimes practically not possible. In this case, connections are so arranged that as we move from low range to higher range, the meter resistance is also increased with the decrease in the value of shunt resistance.

Resistance Measurement by a Multimeter

- ✓ The same basic instrument can be used as an ohmmeter to measure resistances. In this circuit, an internal battery is connected in series with the meter through an adjustable resistance r and the fixed resistances.
- ✓ The fixed resistances limit the current within the desired range, and the variable resistance r is used for zero adjustments. The resistance to be measured (test resistance) is connected between test leads.
- ✓ The current flowing through the circuit depends upon the resistance of the test piece. The deflection of the needle indicates current, but the scale is calibrated in ohms to give the value of resistance directly.

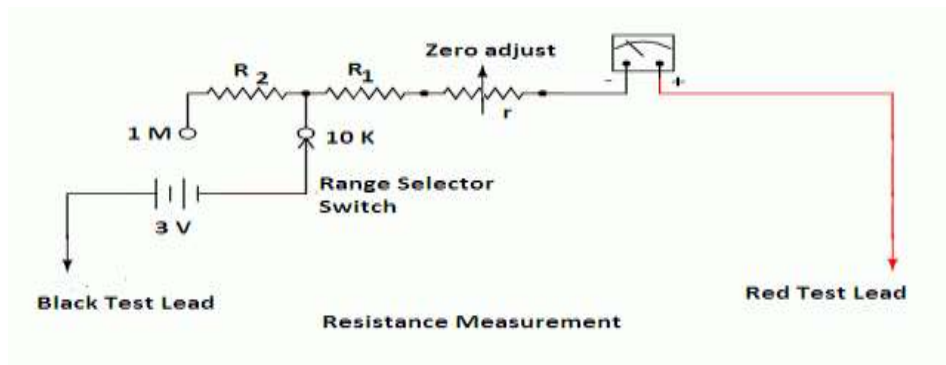

- ✓ To measure resistance by the multimeter, a suitable range is selected. Then the meter leads are shorted, and variable resistance r is adjusted to give full-scale deflection.
- ✓ Under this condition, the resistance between test leads is zero; therefore, the scale of ohmmeter indicates zero on the extreme right end. Then the resistance under measurement is connected between terminals test leads.

Digital Multimeter

A digital multimeter or DMM is test equipment used for resistance, voltage, current measurement and other electrical parameters as per requirement and displaying the results in the mathematical digits form on an LCD or LED readout. It is a type of multimeter which functions digitally.

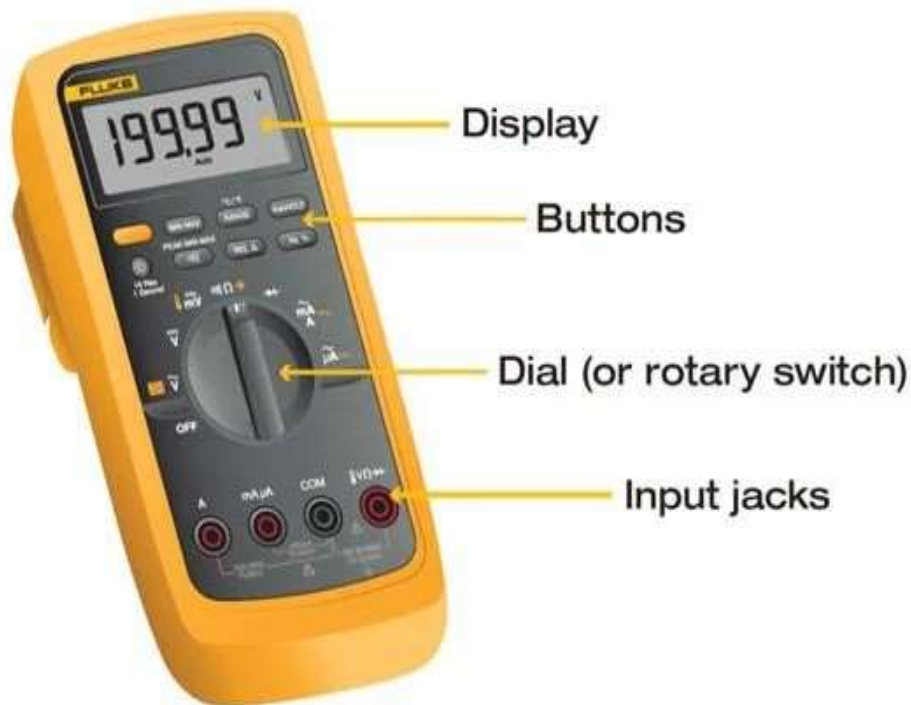

(DIGITAL MULTIMETER)

Block diagram of Digital multimeter

In digital multimeter, we can incorporate many types of meters like ohmmeter, ammeter, a voltmeter for the measurement of electrical parameters. Its block diagram is shown below in the figure. Let us have a look at its working and specification one by one.

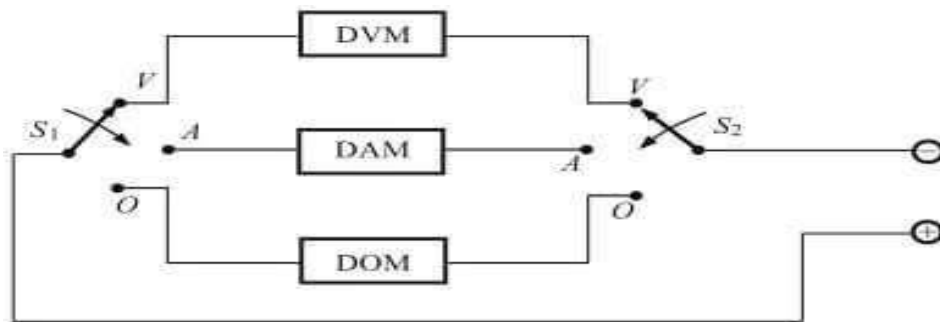

(i) Digital voltmeter (DVM):

Digital voltmeter is the basic instrument used for measurement of voltage through the use of Analog to Digital converter. The basic principle behind digital multimeters is the Analog to digital converter because without this we are not able to convert the analog output into digital form.

(ii) Digital Ammeter (DAM):

Digital ammeter uses a shunt resistor to produce a calibrated voltage proportional to the current flowing. As shown in the diagram, to read the current we must first convert the current to be measured into a voltage by using a known resistance R_k . The voltage so developed is calibrated to read the input current.

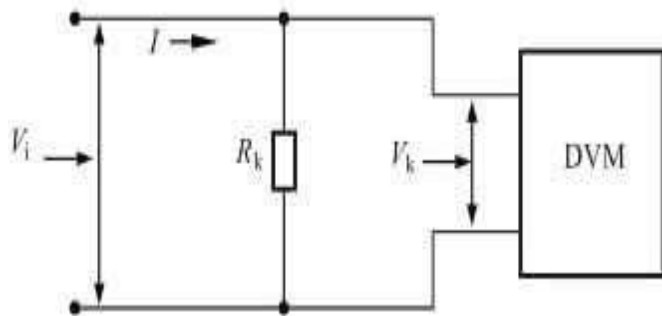

(iii) Digital ohm meter (DOM):

A digital ohmmeter is used to measure electrical resistance which obstructs the path to the flow of current.

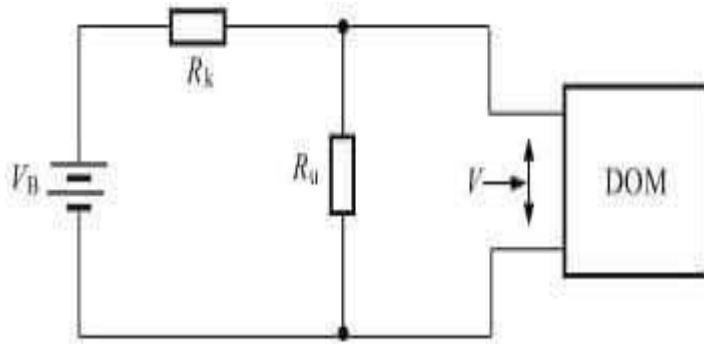

As shown in the diagram, a resistance network comprising of a known resistance R_k and unknown resistance R_u used to develop a voltage across the unknown resistance. The voltage is given by:

$$V = V_B \frac{R_u}{R_k + R_u}$$

Where V_B = Voltage of the battery

Working Principle of Digital Multimeter

As shown in the block diagram, in a typical Digital multimeter the input signal i.e. ac or dc voltage, current, resistance, temperature or any other parameter is converted to dc voltage within the range of the ADC. The analog to digital converter then converts the pre-scaled dc voltage into its equivalent digital numbers which will be displayed on the display unit.

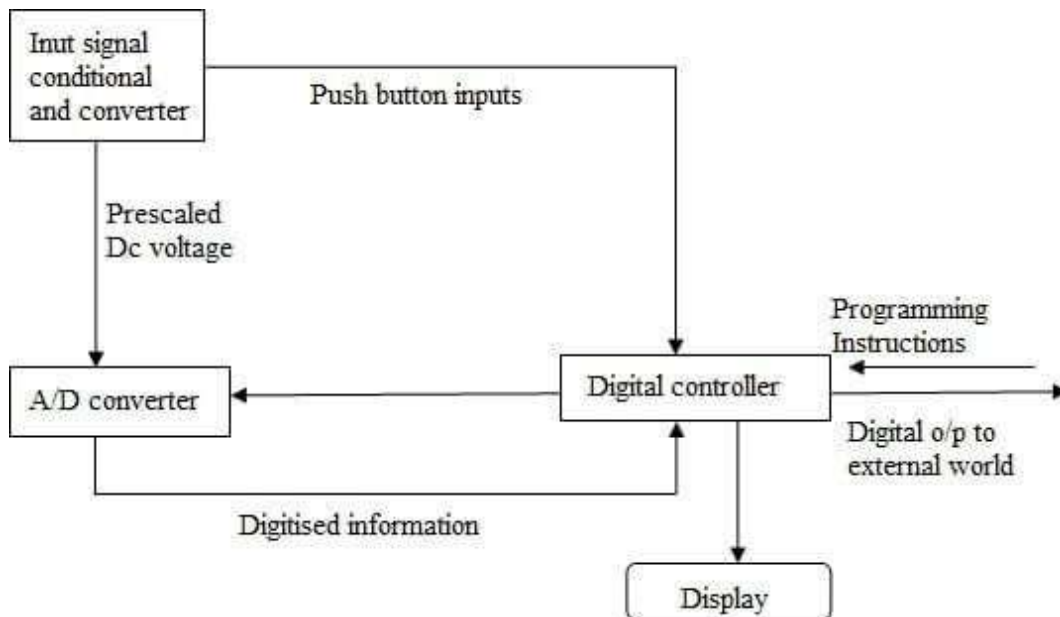

(i) Display:

The LCD screen present on the upper portion of the multimeter basically displays four or more digits and also shows negative value if necessary. A few or today's multimeters have illuminated the display for better viewing in low light situations.

(ii) Selection Dial:

It allows the user to set the multimeter to read different electrical parameters such as milliamps (mA) of current, voltage, resistance, capacitance etc. You can easily turn the dial anywhere for specific parameter measurement.

(iii) Ports:

Two ports are available on the front of every multimeter except in some four ports are available for measuring current in mA or A. We plugged two probes into these ports which are of different colors i.e. one is of red color and other is of black color. Different Ports in multimeter are:

(a) COM:

It stands for common and is almost connected to ground or considered as a -ve connection of a circuit. We generally insert the black color probe into COM port.

(b) mAVΩ:

This port allows the measurement of current (up to 200 mA), voltage and resistance or considered as a +ve connection of a circuit. We generally insert the red color probe into mAVΩ port.

leads:

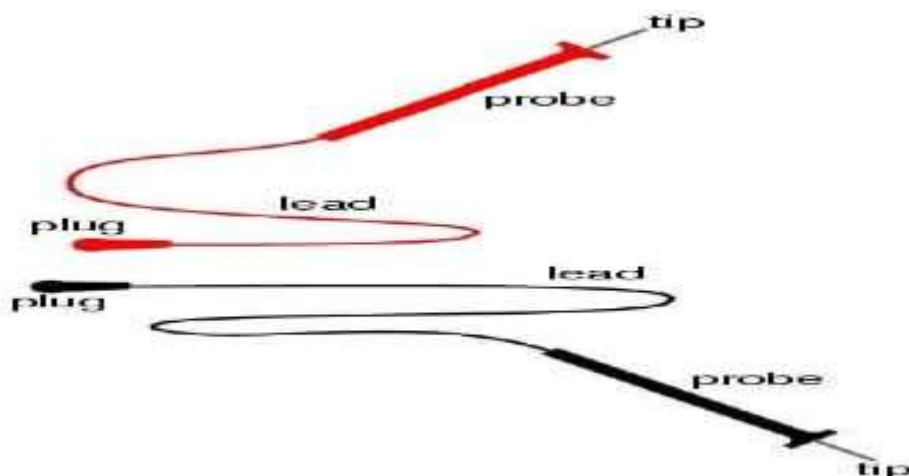

(i) Red lead

- Connected to voltage, resistance or ampere port.
- Considered as a +ve connection of a circuit

(ii) Black lead

- Connected to the common or ground port
- Considered as a -ve connection of a circuit

(iii) Probes: These are the handles used to hold the tip on the tested connection

(iv) Tip: These are present at the end of the probes and basically, provide a connection point

Measurement of inductance by Maxwell's Bridge method:-

The connection diagram and the pharos drawing of Maxwell Inductance Bridge is shown in figure below.

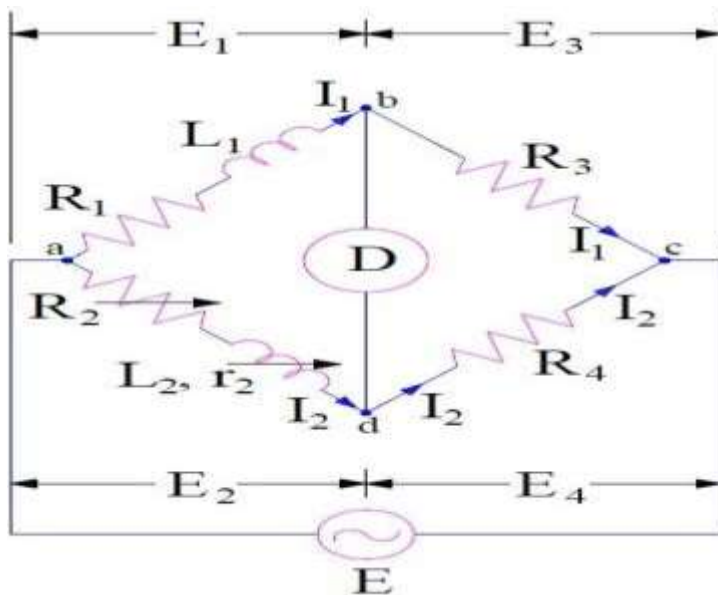

In the above circuit,

L1 = Unknown inductance having resistance **R1**

L2 = Variable standard inductance with fixed resistance **r2**

R2 = Variable resistance

R3 and **R4** = Known resistance

As we know that, for a balanced bridge the multiplication of impedances of opposite arms must be equal.

Impedance of arm ab, **Z1 = (R1+jwL1)**

Impedance of arm cd, **Z2 = R4**

Impedance of arm ad, $Z_3 = (R_2+r_2+j\omega L_2)$

Impedance of arm bc, $Z_4 = R_3$

Hence for balanced bridge,

$$Z_1 Z_2 = Z_3 Z_4$$

$$(R_1+j\omega L_1) \times R_4 = (R_2+r_2+j\omega L_2) \times R_3$$

$$R_1 R_4 - R_2 R_3 - r_2 R_3 + j\omega (L_1 R_4 - L_2 R_3) = 0$$

Equating real and imaginary part we get,

$$R_1 R_4 - R_2 R_3 - r_2 R_3 = 0 \dots\dots\dots(1)$$

$$\text{And } (L_1 R_4 - L_2 R_3) = 0 \dots\dots\dots(2)$$

From (1),

$$\begin{aligned} R_1 R_4 &= R_2 R_3 + r_2 R_3 \\ &= R_3 (R_2 + r_2) \end{aligned}$$

$$\text{Hence, } R_1 = (R_3/R_4) (R_2 + r_2)$$

Now from (2),

$$L_1 R_4 = L_2 R_3$$

$$\text{Hence, } L_1 = L_2 R_3 / R_4$$

Thus unknown inductance L_1 and its resistance R_1 may be calculated.

Measurement of capacitance by Schering Bridge method:-

This bridge is used to measure to the capacitance of the capacitor, dissipation factor and measurement of relative permittivity. Let us consider the circuit of Schering Bridge as shown below:

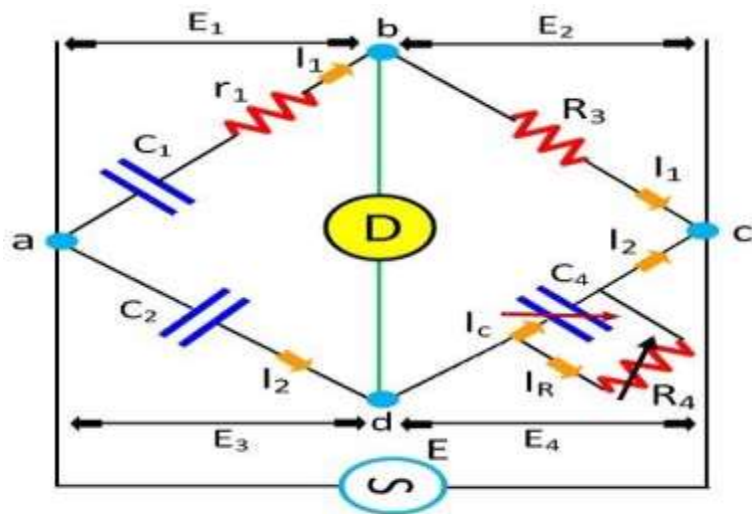

Low Voltage Schering Bridge

Circuit Globe

Let

C_1 = capacitor whose capacitance is to be determined,

r_1 = a series resistance representing the loss in the capacitor C_1

C_2 = a standard capacitor

R_3 = a non – inductive resistance

C_4 = a variable capacitor

R_4 = a variable non-inductive resistance in parallel with variable capacitor C_4

Now when the Schering Bridge is balanced, then

$$\left[r_1 + \frac{1}{j\omega C_1} \right] \left[\frac{R_4}{1 + j\omega C_4 R_4} \right] = \frac{1}{j\omega C_2} \cdot R_3$$

$$\left[r_1 + \frac{1}{j\omega C_1} \right] R_4 = \frac{R_3}{j\omega C_2} (1 + j\omega C_4 R_4)$$

$$r_1 R_4 - \frac{jR_4}{\omega C_1} = -\frac{jR_3}{\omega C_2} + \frac{R_3 R_4 C_4}{C_2}$$

By equating real and imaginary part of the equation we get,

$$r_1 = \frac{R_3 C_4}{C_2}$$

$$\text{and } C_1 \frac{C_2 R_4}{R_3}$$

Two independent balance equations are obtained if C4 and R4 are chosen as the variable elements.

The dissipation factor is given by:

$$\begin{aligned} D_1 &= \tan \delta = \omega C_1 r_1 \\ &= \omega \left(\frac{C_2 R_4}{R_3} \right) \times \left(\frac{R_3 C_4}{C_2} \right) = \omega C_4 R_4 \end{aligned}$$

Therefore values of capacitance C1 and its dissipation factor are obtained from the values of bridge elements at balance.

In the above equation value of R4 and C2 are fixed therefore the dial resistor R3 may be calibrated to read the capacitance directly.

.....

UNIT-8

Sensors and transducers

Transducer- It is defined as an element when subjected to some physical change experiences a related change or an element which converts a specified measure and into a usable output by using a transduction principle. It can also be defined as a device that converts a signal from one form of energy to another form.

Sensor- It is defined as an element which produces signal relating to the quantity being measured.

Sensor/transducers specifications:-

Transducers or measurement systems are not perfect systems. Mechatronics design engineer must know the capability and shortcoming of a transducer or measurement system to properly assess its performance. There are a number of performance related parameters of a transducer or measurement system. These parameters are called as sensor specifications. Sensor specifications inform the user to the about deviations from the ideal behavior of the sensors. Following are the various specifications of a sensor/transducer system.

1. Range- The range of a sensor indicates the limits between which the input can vary. For example, a thermocouple for the measurement of temperature might have a range of 25-225 °C.

2. Span- The span is difference between the maximum and minimum values of the input. Thus, the above-mentioned thermocouple will have a span of 200 °C.

3. Error- Error is the difference between the result of the measurement and the true value of the quantity being measured. A sensor might give a displacement reading of 29.8 mm, when the actual displacement had been 30 mm, then the error is -0.2 mm.

4. Accuracy- The accuracy defines the closeness of the agreement between the actual measurement result and a true value of the measured. It is often expressed as a percentage of the full range output or full-scale deflection. If it is specified with the accuracy of about $\pm 1\%$ full scale, then the reading given can be expected to be within ± 0.7 MPa.

5. Sensitivity- Sensitivity of a sensor is defined as the ratio of change in output value of a sensor to the per unit change in input value that causes the output change.

6. Nonlinearity- The nonlinearity indicates the maximum deviation of the actual measured curve of a sensor from the ideal curve.

Nonlinearity (%) = Maximum deviation in input / Maximum full scale input

7. Hysteresis- The hysteresis is an error of a sensor, which is defined as the maximum difference in output at any measurement value within the sensor's specified range when approaching the point first with increasing and then with decreasing the input parameter.

8. Resolution- Resolution is the smallest detectable incremental change of input parameter that can be detected in the output signal. Resolution can be expressed either as a proportion of the full-scale reading or in absolute terms. For example, if a LVDT sensor measures a displacement up to 20 mm and it provides an output as a number between 1 and 100 then the resolution of the sensor device is 0.2 mm.

9. Stability- Stability is the ability of a sensor device to give same output when used to measure a constant input over a period of time. The term 'drift' is used to indicate the change in output that occurs over a period of time. It is expressed as the percentage of full range output.

10. Dead band/time- The dead band or dead space of a transducer is the range of input values for which there is no output. The dead time of a sensor device is the time duration from the application of an input until the output begins to respond or change.

11. Repeatability- It specifies the ability of a sensor to give same output for repeated applications of same input value. It is usually expressed as a percentage of the full range output: $\text{Repeatability} = \frac{\text{maximum} - \text{minimum values given}}{\text{full range}} \times 100$.

12. Response- Time Response time describes the speed of change in the output on a step-wise change of the measurand. It is always specified with an indication of input step and the output range for which the response time is defined.

Classification of sensors:-

Sensors can be classified into various groups according to the factors such as measurand, application fields, conversion principle, energy domain of the measurand and thermodynamic considerations. These general classifications of sensors are well described

Detail classification of sensors in view of their applications in manufacturing is as follows.

A. Displacement, position and proximity sensors

- Potentiometer
- Strain-gauged element
- Capacitive element
- Differential transformers
- Eddy current proximity sensors
- Inductive proximity switch
- Optical encoders
- Pneumatic sensors
- Proximity switches (magnetic)
- Hall effect sensors

B. Velocity and motion

C. Incremental encoder

- Tachogenerator
- Pyroelectric sensors

D. Force

- Strain gauge load cell

E. Fluid pressure

- Diaphragm pressure gauge
- Capsules, bellows, pressure tubes
- Piezoelectric sensors
- Tactile sensor

F. Liquid flow

- Orifice plate
- Turbine meter

G. Liquid level

- Floats
- Differential pressure

H. diodes and transistors

- Thermocouples
- Light sensors
- Photo diodes
- Photo resistors
- Photo transistor

Potentiometer:-

Shows the construction of a rotary type potentiometer sensor employed to measure the linear displacement.

The potentiometer can be of linear or angular type. It works on the principle of conversion of mechanical displacement into an electrical signal.

The sensor has a resistive element and a sliding contact (wiper). The slider moves along this conductive body, acting as a movable electric contact.

The object of whose displacement is to be measured is connected to the slider by using

- ✓ a rotating shaft (for angular displacement)
- ✓ a moving rod (for linear displacement)
- ✓ a cable that is kept stretched during operation

The resistive element is a wire wound track or conductive plastic. The track comprises of large number of closely packed turns of a resistive wire.

Conductive plastic is made up of plastic resin embedded with the carbon powder. Wire wound track has a resolution of the order of $\pm 0.01\%$ while the conductive plastic may have the resolution of about $0.1\ \mu\text{m}$.

During the sensing operation, a voltage V_s is applied across the resistive element. A voltage divider circuit is formed when slider comes into contact with the wire.

The output voltage (V_A) is measured as shown in the. The output voltage is proportional to the displacement of the slider over the wire. Then the output parameter displacement is calibrated against the output voltage V_A .

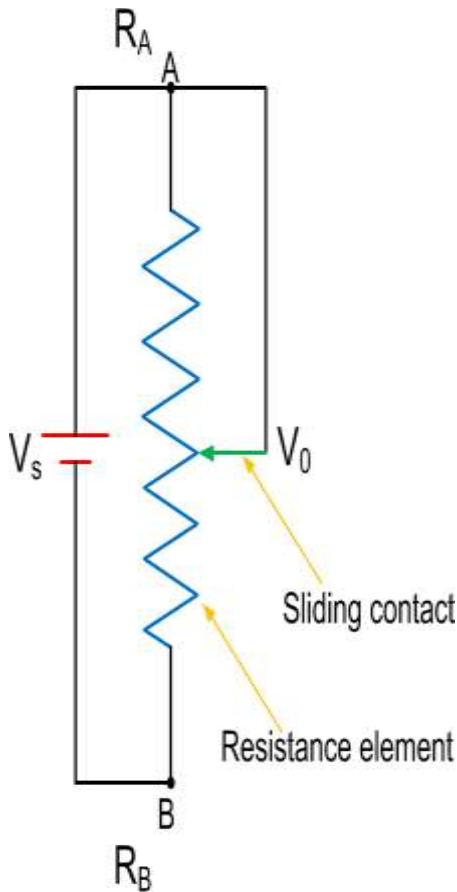

$$V_A = I R_A \dots\dots\dots(1)$$

$$\text{But } I = V_S / (R_A + R_B) \dots\dots\dots(2)$$

$$\text{Therefore } V_A = V_S R_A / (R_A + R_B) \dots\dots\dots(3)$$

As we know that $R = \rho L / A$, where ρ is electrical resistivity, L is length of resistor and A is area of cross section

$$V_A = V_S L_A / (L_A + L_B) \dots\dots\dots(4)$$

Applications of potentiometer

- ✓ These sensors are primarily used in the control systems with a feedback loop to ensure that the moving member or component reaches its commanded position.
- ✓ These are typically used on machine-tool controls, elevators, liquid-level assemblies, forklift trucks, automobile throttle controls. In manufacturing, these are used in control of injection molding machines, woodworking machinery, printing, spraying, robotics, etc. These are also used in computer-controlled monitoring of sports equipment.

Strain Gauges:-

The strain in an element is a ratio of change in length in the direction of applied load to the original length of an element. The strain changes the resistance R of the element. Therefore, we can say,
 $\Delta R/R \propto \epsilon$;

$$\Delta R/R = G \epsilon \dots \dots \dots (1)$$

Where G is the constant of proportionality and is called as gauge factor. In general, the value of G is considered in between 2 to 4 and the resistances are taken of the order of 100Ω .

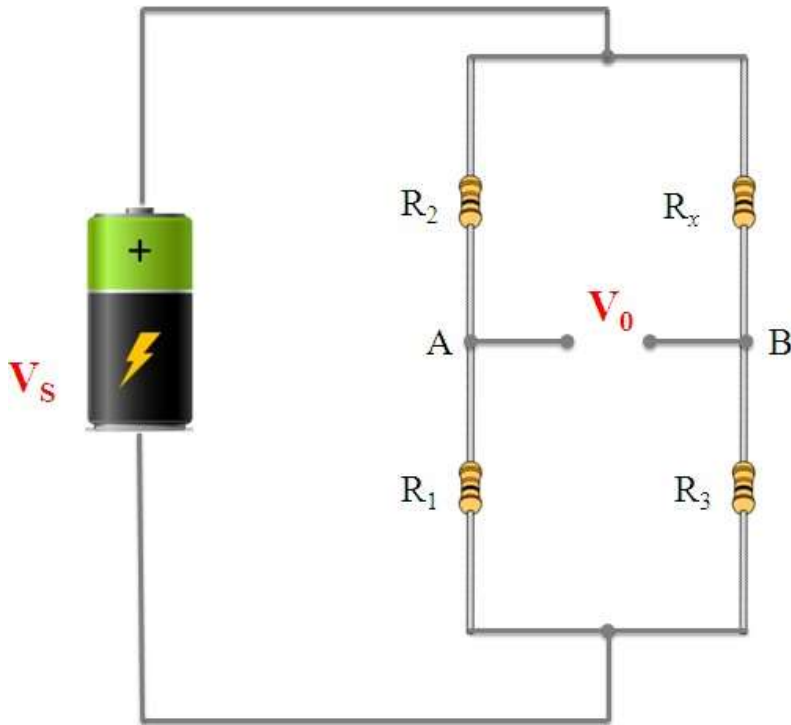

- ✓ Resistance strain gauge follows the principle of change in resistance as per the equation 1. It comprises of a pattern of resistive foil arranged as shown in Figure.
- ✓ These foils are made of Constantan alloy (copper-nickel 55-45% alloy) and are bonded to a backing material plastic (polyimide), epoxy or glass fiber reinforced epoxy.
- ✓ As the work piece undergoes change in its shape due to external loading, the resistance of strain gauge element changes.
- ✓ This change in resistance can be detected by a using a Wheatstone's resistance bridge as shown in Figure In the balanced bridge we can have a relation,
- ✓ $R_2/R_1 = R_x / R_3 \dots \dots \dots (2)$
- ✓ Where R_x is resistance of strain gauge element, R_2 is balancing/adjustable resistor, R_1 and R_3 are known constant value resistors.
- ✓ The measured deformation or displacement by the stain gauge is calibrated against change in resistance of adjustable resistor R_2 which makes the voltage across nodes A and B equal to zero.

Applications of strain gauges

- ✓ Strain gauges are widely used in experimental stress analysis and diagnosis on machines and failure analysis. They are basically used for multi-axial stress fatigue testing, proof testing, residual stress and vibration measurement, torque measurement, bending and deflection measurement, compression and tension measurement and strain measurement.
- ✓ Strain gauges are primarily used as sensors for machine tools and safety in automotive. In particular, they are employed for force measurement in machine tools, hydraulic or pneumatic press and as impact sensors in aerospace vehicles.

Thermistors:-

- ✓ Thermistors follow the principle of decrease in resistance with increasing temperature.
- ✓ The material used in thermistor is generally a semiconductor material such as a sintered metal oxide (mixtures of metal oxides, chromium, cobalt, iron, manganese and nickel) or doped polycrystalline ceramic containing barium Titanate (BaTiO_3) and other compounds.
- ✓ As the temperature of semiconductor material increases the number of electrons able to move about increases which results in more current in the material and reduced resistance.
- ✓ Thermistors are rugged and small in dimensions. They exhibit nonlinear response characteristics.
- ✓ Thermistors are available in the form of a bead (pressed disc), probe or chip. Figure shows the construction of a bead type thermistor.
- ✓ It has a small bead of dimension from 0.5 mm to 5 mm coated with ceramic or glass material. The bead is connected to an electric circuit through two leads.
- ✓ To protect from the environment, the leads are contained in a stainless steel tube.

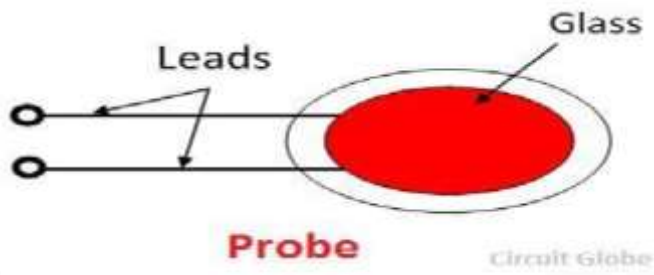

Applications of Thermistors:-

- To monitor the coolant temperature and/or oil temperature inside the engine
- To monitor the temperature of an incubator
- Thermistors are used in modern digital thermostats
- To monitor the temperature of battery packs while charging
- To monitor temperature of hot ends of 3D printers
- To maintain correct temperature in the food handling and processing industry equipment
- To control the operations of consumer appliances such as toasters, coffee makers, refrigerators, freezers, hair dryers, etc.

Resistance temperature detectors (RTDs):-

RTDs work on the principle that the electric resistance of a metal changes due to change in its temperature. On heating up metals, their resistance increases and follows a linear relationship as shown in Figure. The correlation is

$$R_t = R_0 (1 + \alpha T)$$

Where R_t is the resistance at temperature T ($^{\circ}\text{C}$) and R_0 is the temperature at 0°C and α is the constant for the metal termed as temperature coefficient of resistance. The sensor is usually made to have a resistance of $100\ \Omega$ at $0\ ^{\circ}\text{C}$.

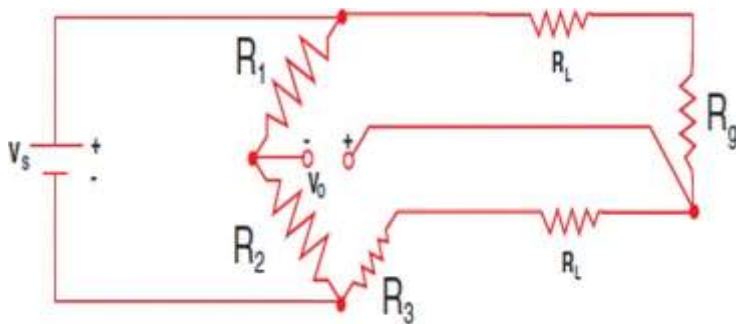

Fig.6. Circuitry view of three wires RTD Bridge

Figure shows the construction of a RTD. It has a resistor element connected to a Wheatstone bridge. The element and the connection leads are insulated and protected by a sheath. A small amount of current is continuously passing through the coil. As the temperature changes the resistance of the coil changes which is detected at the Wheatstone bridge.

RTDs are used in the form of thin films, wire wound or coil. They are generally made of metals such as platinum, nickel or nickel-copper alloys. Platinum wire held by a high-temperature glass adhesive in a ceramic tube is used to measure the temperature in a metal furnace.

Applications of RTD:-

- Air conditioning and refrigeration servicing
- Food Processing
- Stoves and grills
- Textile production
- Plastics processing
- Petrochemical processing
- Micro electronics
- Air, gas and liquid temperature measurement in pipes and tanks
- Exhaust gas temperature measurement.

Linear Variable Displacement Transducer (LVDT):-

A very basic transducer which is always useful in the field of instrumentation, I have studied about this in my college days. Now let me explain about the LVDT with its Principle of Operation and I will explain how it is constructed for its well known operation and you can understand the working of LVDT.

Principle of LVDT:-

LVDT works under the principle of mutual induction, and the displacement which is a non-electrical energy is converted into an electrical energy. And the way how the energy is getting converted is described in working of LVDT in a detailed manner.

Construction of LVDT:-

LVDT consists of a cylindrical former where it is surrounded by one primary winding in the center of the former and the two secondary windings at the sides. The number of turns in both the secondary windings are equal, but they are opposite to each other, i.e., if the left secondary windings is in the clockwise direction, the right secondary windings will be in the anti-clockwise direction, hence the net output voltages will be the difference in voltages between the two secondary coil. The two secondary coil is represented as S1 and S2. Esteem iron core is placed in the center of the cylindrical former which can move in to and fro motion as shown in the figure. The AC excitation voltage is 5 to 12V and the operating frequency is given by 50 to 400 HZ.

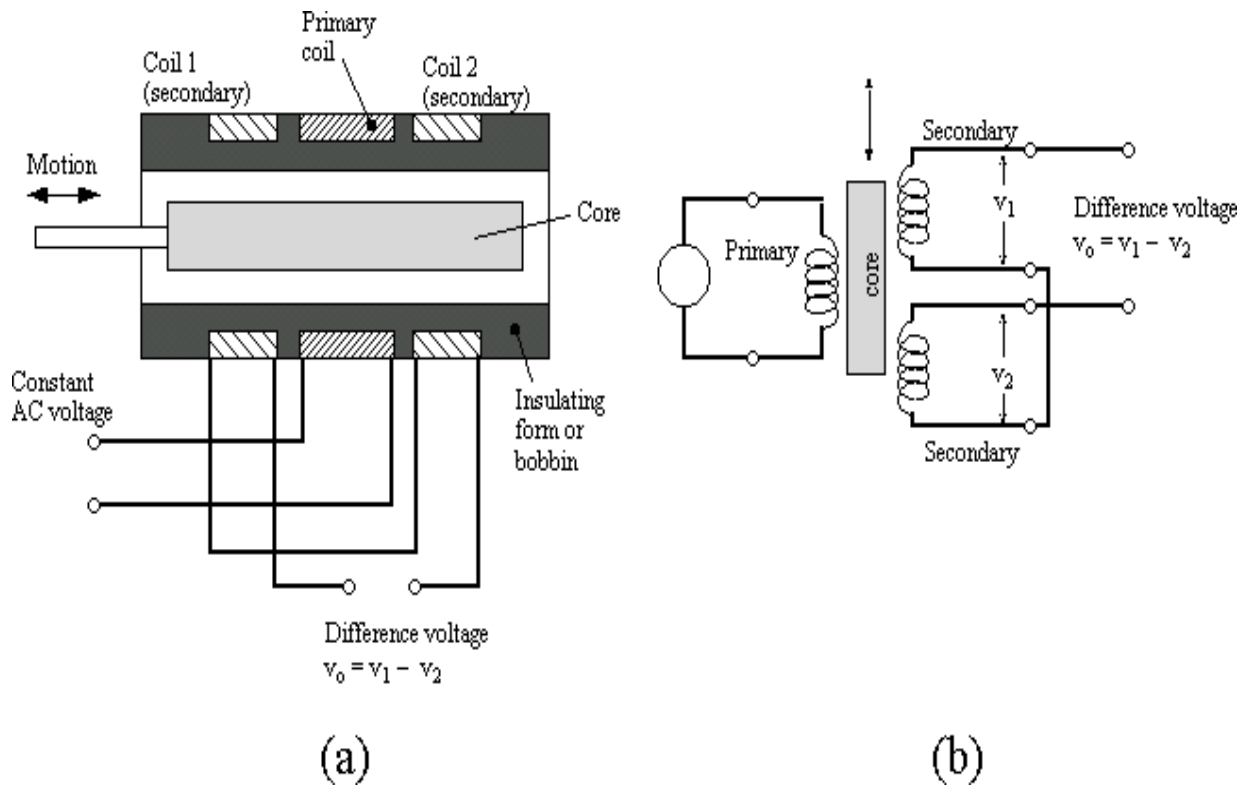

Working of LVDT:-

Let's study the working of LVDT by splitting the cases into 3 based on the iron core position inside the insulated former.

Case 1: On applying an external force which is the displacement, if the core remains in the null position itself without providing any movement then the voltage induced in both the secondary windings are equal which results in net output is equal to zero i.e., $E_{sec1} - E_{sec2} = 0$

Case 2: When an external force is applied and if the steel iron core tends to move in the left hand side direction then the emf voltage induced in the secondary coil is greater when compared to the emf induced in the secondary coil 2. Therefore the net output will be $E_{sec1} - E_{sec2}$

Case 3: When an external force is applied and if the steel iron core moves in the right hand side direction then the emf induced in the secondary coil 2 is greater when compared to the emf voltage induced in the secondary coil 1. Therefore the net output voltage will be $E_{sec2} - E_{sec1}$.

Applications of LVDT:

LVDT is used to measure displacement ranging from fraction millimeter to centimeter. Acting as a secondary transducer, LVDT can be used as a device to measure force, weight and pressure, etc.

Capacitive Transducer:-

Definition: The capacitive [transducer](#) is used for measuring the displacement, pressure and other physical quantities. It is a passive transducer that means it requires external power for operation. The capacitive transducer works on the principle of variable [capacitances](#). The capacitance of the capacitive transducer changes because of many reasons like overlapping of plates, change in distance between the plates and dielectric constant.

The capacitive transducer contains two parallel metal plates. These plates are separated by the dielectric medium which is either air, material, gas or liquid. In the normal capacitor the distance between the plates are fixed, but in capacitive transducer the distance between them are varied.

The capacitive transducer uses the electrical quantity of capacitance for converting the mechanical movement into an electrical signal. The input quantity causes the change of the capacitance which is directly measured by the capacitive transducer.

The capacitors measure both the static and dynamic changes. The displacement is also measured directly by connecting the measurable devices to the movable plate of the capacitor. It works on with both the contacting and non-contacting modes.

Principle of Operation:-

$$C = \epsilon A/d$$

$$C = \epsilon_r \epsilon_0 A/d$$

The equations below express the capacitance between the plates of a capacity

Where

A – Overlapping area of plates in m²

d – the distance between two plates in meter

ϵ – permittivity of the medium in F/m

ϵ_r – relative permittivity

ϵ_0 – the permittivity of free space.

The schematic diagram of a parallel plate capacitive transducer is shown in the figure below.

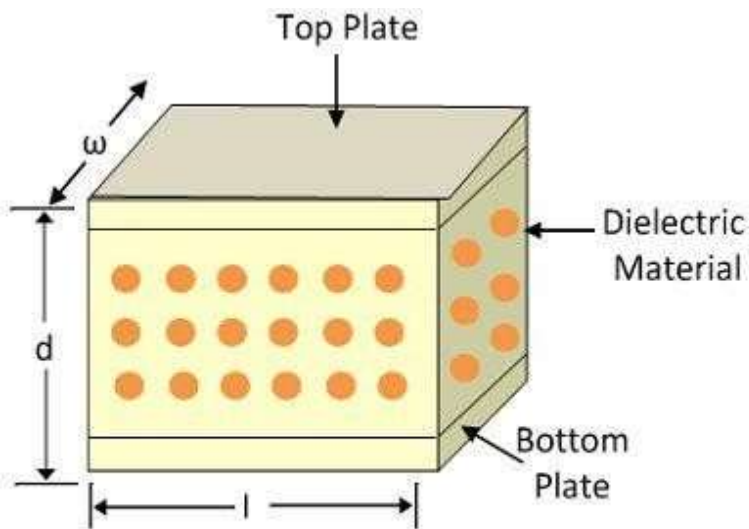

Parallel Plate Capacitive Transducer

Circuit Globe

The change in capacitance occurs because of the physical variables like displacement, force, pressure, etc. The capacitance of the transducer also changes by the variation in their dielectric constant which is usually because of the measurement of liquid or gas level.

The capacitance of the transducer is measured with the bridge circuit. The output impedance of transducer is given as

$$X_c = 1/2\pi fc$$

Where,

C – Capacitance

f – frequency of excitation in Hz.

The capacitive transducer is mainly used for measurement of linear displacement. The capacitive transducer uses the following three effects.

1. Variation in capacitance of transducer is because of the overlapping of capacitor plates.
2. The change in capacitance is because of the change in distances between the plates.
3. The capacitance changes because of dielectric constant.

The following methods are used for the measuring displacement.

1. A transducer using the change in the Area of Plates –

The equation below shows that the capacitance is directly proportional to the area of the plates. The capacitance changes correspondingly with the change in the position of the plates.

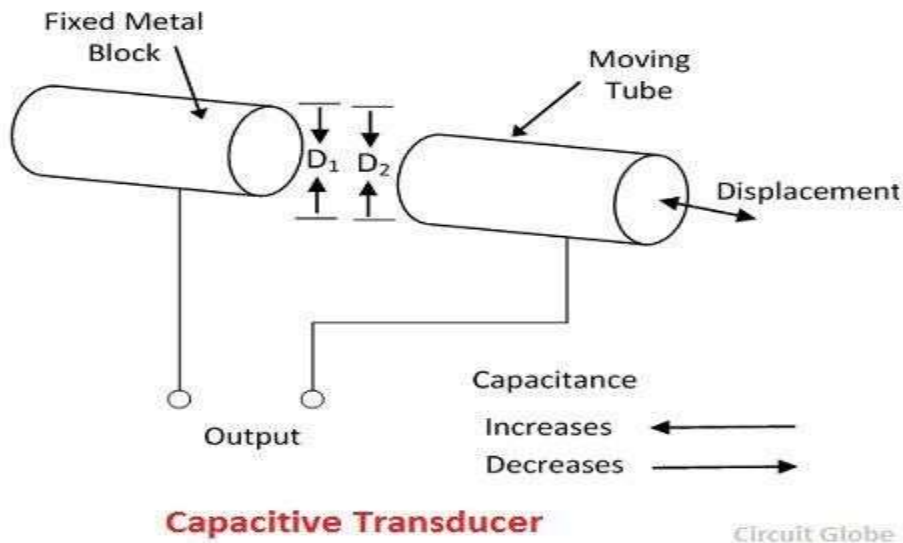

The capacitive transducers are used for measuring the large displacement approximately from 1mm to several cms. The area of the capacitive transducer changes linearly with the capacitance and the displacement. Initially, the nonlinearity occurs in the system because of the edges. Otherwise, it gives the linear response. The capacitance of the parallel plates is given as

$$C = \frac{\epsilon A}{d} = \frac{\epsilon x \omega}{d} F$$

Where

x – the length of overlapping part of plate's
 ω – the width of overlapping part of plates.

The sensitivity of the displacement is constant, and therefore it gives the linear relation between the capacitance and displacement.

$$S = \frac{\partial C}{\partial x} = \epsilon \frac{\omega}{d} F/m$$

2. The transducer using the change in distance between the plates –

The capacitance of the transducer is inversely proportional to the distance between the plates. The one plate of the transducer is fixed, and the other is movable. The displacement which is to be measured links to the movable plates.

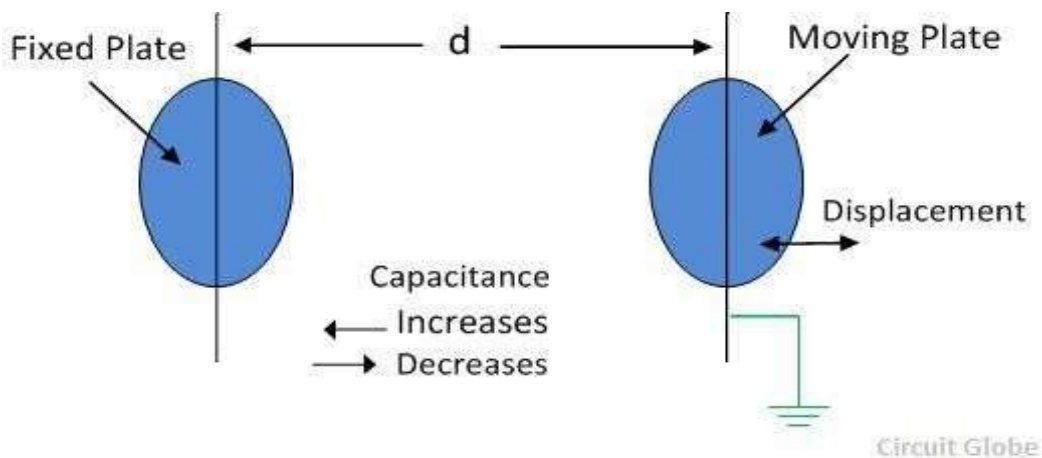

The capacitance is inversely proportional to the distance because of which the capacitor shows the nonlinear response. Such type of transducer is used for measuring the small displacement. The phasor diagram of the capacitor is shown in the figure below.

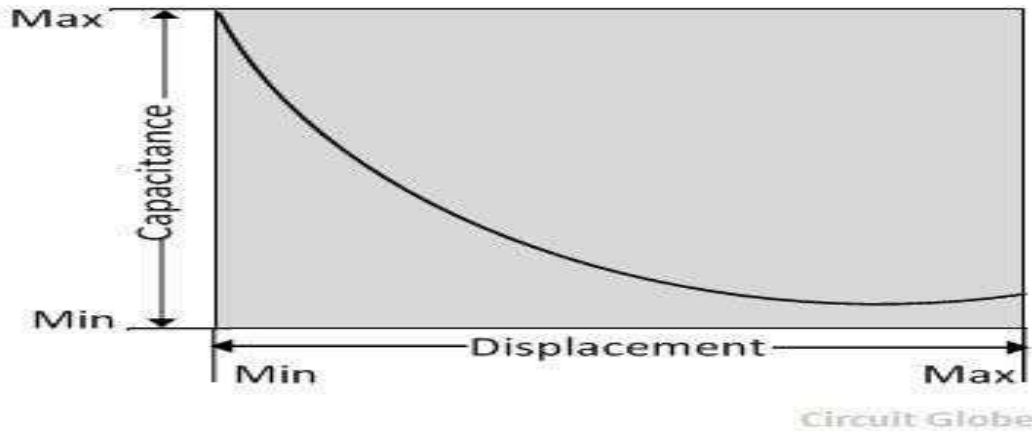

The sensitivity of the transducer is not constant and vary from places to places.

Uses of Capacitive Transducer:-

1. The capacitive transducer uses for measurement of both the linear and angular displacement. It is extremely sensitive and used for the measurement of very small distance.
2. It is used for the measurement of the force and pressures. The force or pressure, which is to be measured is first converted into a displacement, and then the displacement changes the capacitances of the transducer.
3. It is used as a pressure transducer in some cases, where the dielectric constant of the transducer changes with the pressure.
4. The humidity in gases is measured through the capacitive transducer.
5. The transducer uses the mechanical modifier for measuring the volume, density, weight etc.

Piezoelectric Transducer:-

Piezoelectric sensor is used for the measurement of pressure, acceleration and dynamic-forces such as oscillation, impact, or high speed compression or tension. It contains piezoelectric ionic crystal materials such as Quartz. On application of force or pressure these materials get stretched or compressed. During this process, the charge over the material changes and redistributes. One face of the material becomes positively charged and the other negatively charged. The net charge q on the surface is proportional to the amount x by which the charges have been displaced. The displacement is proportion to force. Therefore we can write,

$$q = kx = SF \dots \dots \dots (1)$$

Where k is constant and S is a constant termed the charge sensitivity.

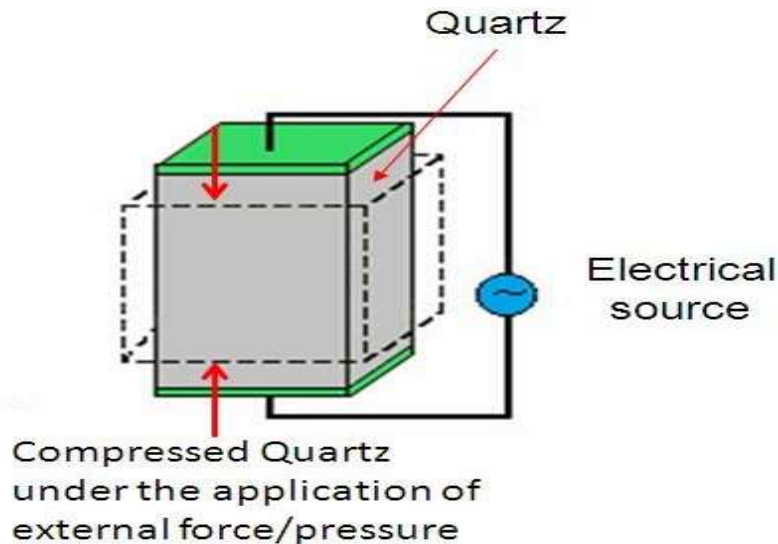

Application of Piezoelectric Materials:-

1. In microphones, the sound pressure is converted into an electric signal and this signal is ultimately amplified to produce a louder sound.
2. Automobile seat belts lock in response to a rapid deceleration is also done using a piezoelectric material.
3. It is also used in medical diagnostics.
4. It is used in electric lighter used in kitchens.
5. Used in fertility treatment.
6. Used in Inkjet printers.

Hall Effect Transducer:-

Definition: The Hall Effect element is a type of transducer used for measuring the magnetic field by converting it into an emf. The direct measurement of the magnetic field is not possible. Thus the Hall Effect Transducer is used. The transducer converts the magnetic field into an electric quantity which is easily measured by the analogue and digital meters.

Principle of Hall Effect Transducer:-

The principle of Hall Effect transducer is that if the current carrying strip of the conductor is placed in a transverse magnetic field, then the EMF develops on the edge of the conductor. The magnitude of the developed voltage depends on the density of flux, and this property of a conductor is called the Hall Effect. The Hall Effect element is mainly used for magnetic measurement and for sensing the current.

The metal and the semiconductor has the property of hall effect which depends on the densities and the mobility of the electrons.

Consider the Hall Effect element shown in the figure below. The current supply through the lead 1 and 2 and the output is obtained from the strip 3 and 4. The lead 3 and 4 are at same potential when no field is applied across the strip.

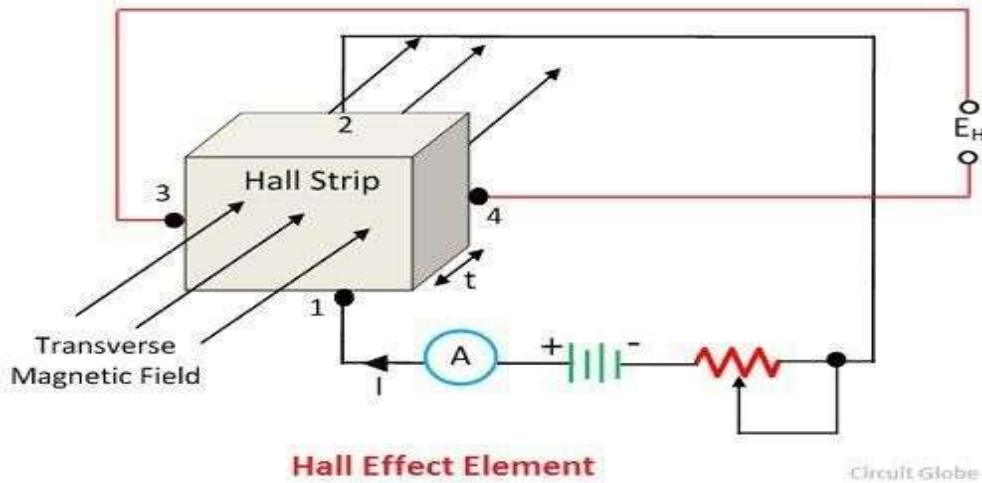

When the magnetic field is applied to the strip, the output voltage develops across the output leads 3 and 4. The develops voltage is directly proportional to the strength of the material.

The output voltage is,

$$E_H = K_H IB/t$$

Where,

$$K_H - \text{Hall effect coefficient ; } \frac{V - m}{A - Wbm^{-2}}$$

$$t - \text{thickness of Strip ; } m$$

The I is the current in ampere and the B is the flux densities in Wb/m²

The current and magnetic field strength both can be measured with the help of the output voltages. The Hall Effect EMF is very small in conductors because of which it is difficult to measure. But a semiconductor like germanium produces large EMF which is easily measured by the moving coil instrument.

Applications of Hall Effect Transducer:-

1. Magnetic to Electric Transducer.
2. Measurement of Displacement.
3. Measurement of Current.
4. Measurement of Power.

.....

UNIT-8

OSCILLOSCOPE

Cathode Ray Tube (CRT)

Definition: The CRT is a display screen which produces images in the form of the video signal. It is a type of vacuum tube which displays images when the electron beam through electron guns are strikes on the phosphorescent surface.

Working of CRT:-

The working of CRT depends on the movement of electrons beams. The electron guns generate sharply focused electrons which are accelerated at high voltage. This high-velocity electron beam when strikes on the fluorescent screen creates luminous spot.

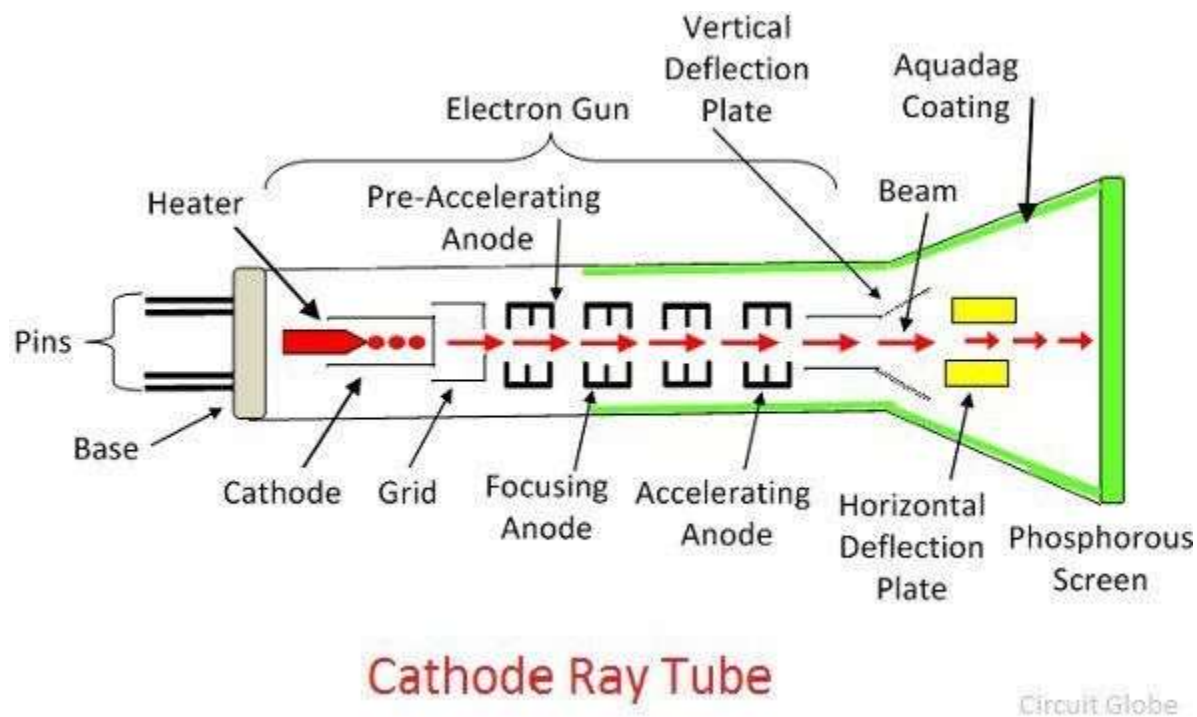

After exiting from the electron gun, the beam passes through the pairs of electrostatic deflection plate. These plates deflected the beams when the voltage applied across it. The one pair of plate moves the beam upward and the second pair of plate moves the beam from one side to another. The horizontal and vertical movement of the electron are independent of each other, and hence the electron beam positioned anywhere on the screen.

The working parts of a CRT are enclosed in a vacuum glass envelope so that the emitted electron can easily move freely from one end of the tube to the other.

Construction of CRT

The Electrons Gun Assembly, Deflection Plate Assembly, Fluorescent Screen, Glass Envelope, Base are the important parts of the CRT. The electron gun emits the electron beam, and through deflecting plates, it strikes on the phosphorous screen. The detail explanation of their parts is explained below.

Electrons Gun Assembly

The electron gun is the source of the electron beams. The electron gun has a heater, cathode, grid, pre-accelerating anode, focusing anode and accelerating anode. The electrons are emitted from the highly emitted cathode. The cathode is cylindrical in shape, and at the end of it, the layer of strontium and barium oxide is deposited which emit the high emission of electrons at the end of the tube.

Electrostatic Deflection Plates

The deflection plate produces the uniform electrostatic field only in the one direction. The electron beam entering into the deflection plates will accelerate only in the one direction, and hence electrons will not move in the other directions.

Screen for CRT

The front of the CRT is called the face plate. The face plate of the CRT is made up of entirely fiber optics which has special characteristics. The internal surface of the faceplate is coated with the phosphor. The phosphorous converts the electrical energy into light energy. The energy level of the phosphorous crystal raises when the electron beams strike on it. This phenomenon is called cathodoluminescence.

The light which is emitted through phosphorous excitation is called fluorescence. When the electron beam stop, the phosphorous crystal regain their original position and release a quantum of light energy which is called phosphorescence or persistence.

Aquadag

The Aquadag is the aqueous solution of graphite which is connected to the secondary of the anode. The Aquadag collects the secondary emitted electrons which are necessary for keeping the CRT screen in the state of electrical equilibrium.

Principle of operation of Oscilloscope with block diagram:-

Oscilloscope is an electronic equipment, which displays a voltage waveform. Among the oscilloscopes, Cathode Ray Oscilloscope (CRO) is the basic one and it displays a time varying signal or waveform.

Block Diagram of CRO

Cathode Ray Oscilloscope (CRO) consists a set of blocks. Those are vertical amplifier, delay line, trigger circuit, time base generator, horizontal amplifier, Cathode Ray Tube (CRT) & power supply. The block diagram of CRO is shown in below figure.

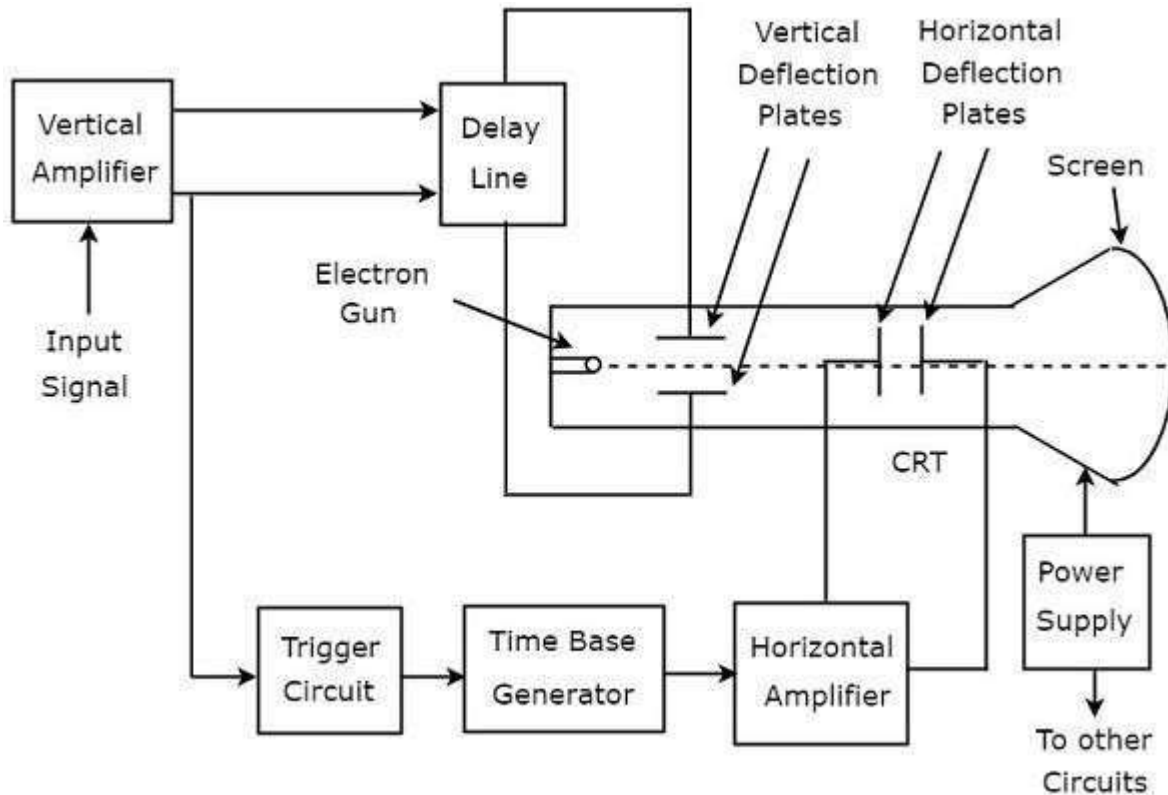

The function of each block of CRO is mentioned below.

- **Vertical Amplifier** – It amplifies the input signal, which is to be displayed on the screen of CRT.
- **Delay Line** – It provides some amount of delay to the signal, which is obtained at the output of vertical amplifier. This delayed signal is then applied to vertical deflection plates of CRT.
- **Trigger Circuit** – It produces a triggering signal in order to synchronize both horizontal and vertical deflections of electron beam.
- **Time base Generator** – It produces a saw tooth signal, which is useful for horizontal deflection of electron beam.
- **Horizontal Amplifier** – It amplifies the saw tooth signal and then connects it to the horizontal deflection plates of CRT.
- **Power supply** – It produces both high and low voltages. The negative high voltage and positive low voltage are applied to CRT and other circuits respectively.

•**Cathode Ray Tube (CRT)** – It is the major important block of CRO and mainly consists of four parts. Those are electron gun, vertical deflection plates, horizontal deflection plates and fluorescent screen.

└The electron beam, which is produced by an electron gun gets deflected in both vertical and horizontal directions by a pair of vertical deflection plates and a pair of horizontal deflection plates respectively. Finally, the deflected beam will appear as a spot on the fluorescent screen.

└In this way, CRO will display the applied input signal on the screen of CRT. So, we can analyze the signals in time domain by using CRO.

We can do the following measurements by using CRO.-

- ✓ Measurement of Amplitude
- ✓ Measurement of Time Period
- ✓ Measurement of Frequency

Measurement of Voltage Current and Frequency (AC)

Normally, an oscilloscope is an important tool in an electrical field which is used to display the graph of an electrical signal as it varies with respect to time. But some of the scopes have additional features apart from their fundamental use. Many oscilloscopes have the measurement tool that help us to measure waveform characteristics like frequency, voltage, amplitude, and many more features with accuracy. Generally, a scope can measure time-based as well as voltage-based characteristics.

Voltage Measurement

The oscilloscope is mainly voltage oriented device or we can say that it is a voltage measuring device. Voltage, current and resistance all are internally related to each other.

Just measure the voltage, rest of the values is obtained by calculation. Voltage is the amount of electric potential between two points in a circuit. It is measured from peak-to-peak amplitude which measures the absolute difference between the maximum point of signal and its minimum point of the signal. The scope displays exactly the maximum and minimum voltage of the signal received. After measuring all high and low voltage points, scope calculates the average of the minimum and maximum voltage. But you must be careful to mention which voltage you mean. Normally, oscilloscope has fixed input range, but this can be easily increased with the use of simple potential divider circuit.

Method to Measure Voltage

1. The simplest way to measure signal is to set the trigger button to auto that means oscilloscope start to measure the voltage signal by identifying the zero voltage point or peak voltage by itself. As any of these two points identified the oscilloscope triggers and measure the range of the voltage signal.

2. Vertical and horizontal controls are adjusted so that the displayed image of the sine wave is clear and stable. Now take measurements along the center vertical line which has the smallest divisions. Reading of the voltage signal will be given by vertical control.

Current Measurement

Electrical current cannot be measured directly by an oscilloscope. However, it could be measured indirectly within scope by attaching probes or resistors. Resistor measures the voltage across the points and then substituting the value of voltage and resistance in Ohm's law and calculates the value of electrical current. Another easy way to measure current is to use a clamp-on current probe with an oscilloscope.

Method to Measure Current

1. Attach a probe with the resistor to an electrical circuit. Make sure that resistor's power rating should be equal or greater than the power output of the system.
2. Now take the value of resistance and plug into Ohm's Law to calculate the current.

According to Ohm's Law,

$$I=V/R$$

Frequency Measurement

Frequency can be measured on an oscilloscope by investigating the frequency spectrum of a signal on the screen and making a small calculation. Frequency is defined as the several times a cycle of an observed wave takes up in a second. The maximum frequency of a scope can measure may vary but it always in the 100's of MHz range. To check the performance of response of signals in a circuit, scope measures the rise and fall time of the wave.

Method to Measure Frequency

1. Increase the vertical sensitivity to get the clear picture of the wave on the screen without chopping any of its amplitude off.
2. Now adjust the sweep rate in such a way that screen displays a more than one but less than two complete cycles of the wave.
3. Now count the number of divisions of one complete cycle on the graticule from start to end.
4. Now take horizontal sweep rate and multiply it with the number of units that you counted for a cycle. It will give you the period of the wave. The period is the number of seconds each repeating waveform takes. With the help of period, you can simply calculate the frequency in cycles per second (Hertz).

.....